



40RUM Packaged Air Handler Units – 60Hz



Quality Assurance
Certificate Reg. No:
04 100 950420



Subject to change without notice

Product Data Catalog

Manufacturer's Name: Saudi Airconditioning Manufacturing Co. Ltd.

Country of origin : Jeddah, Saudi Arabia

Nearest port of embarkation: Jeddah Islamic port

Product classification: Commercial and Residential

40RUM Packaged Air Handler Units – 60Hz

Unit Size 6.0 – 28.0 Tons

HFC R-410A Refrigerant

The 40RUM Series air-handling units are the best choice for packaged air handlers. Model 40RUM units have direct-expansion coils. All models offer excellent fan performance, a unique combination of indoor air quality features, easy installation, and affordable prices. Their versatility and state-of-the-art features will provide economical performance now and in the future.

Contact your local Carrier representative for additional reference materials. www.carrier.com

TABLE OF CONTENTS

Features / Benefits.....	2
Model No. Nomenclature	4
AHRI Capacity Ratings	5
Unit Physical Data.....	6
Options and Accessories	8
Base Unit Dimensions	10
Dimensions Corner Weight.....	13
Accessory Dimensions	14
Selection Procedure/Controls	18
Cooling Capacities	19
Fan Performance Data	21
Performance Data.....	23
Electrical Data / Electric Heater Data	24
Typical Wiring Schematic	28
Typical Piping and Wiring	29
Application Data.....	32
Guide Specifications	34

FEATURES / BENEFITS

Every compact one-piece unit arrives fully assembled, charged, tested, and ready to run.

Carrier's air-cooled air conditioning split systems:

- Provide a logical solution for commercial needs
- Have a rugged, dependable construction
- Are available in single and circuit scroll compressor capacity control
- Have cooling capability up to 125°F (52°C) ambient and down to 40°F (4°C) ambient standard

Constructed for long life

The 38AUMZ single circuit and 38AUMD dual circuit, scroll compressor models are designed and built to last. The high efficient designed outdoor coil construction allows for a more efficient design in a smaller cabinet size that utilizes an overall reduction in refrigerant charge. Where conditions require, special coil coating coil protection option is available. Cabinets are constructed of pre-painted galvanized steel, delivering unparalleled protection from the environment. Inside and outside surfaces are protected to ensure long life, good looks, and reliable operation. Safety controls are used for enhanced system protection and reliability.

Efficient operation

These air cooled condensing units will provide EER's up to 11.5 which meets ASHRAE 90.1 efficiency levels. The 38AUMD dual compressor models provide two (2) stages of cooling for remarkable partial load performance. This high efficiency will help reduce overall operating cost and energy consumption.

Innovative Carrier 40RUM packaged air handlers are custom matched to 38AUMZ/D condensing units

Information on matching 40RUM DX packaged air handler follows for convenience. See separate product data for more details. The 40RUM Series has excellent fan performance, efficient direct-expansion (DX) coils, a unique combination of indoor-air quality features, and is easy to install. Its versatility and state-of-the-art features help to ensure economical performance of the split system both now and in the future.

Rugged dependability

The 40RUM series units are made to last. The die-formed galvanized steel panels ensure structural integrity under all operating conditions. Galvanized steel fan housings are securely mounted to a die-formed galvanized steel fan deck. Rugged pillow-block bearings (40RUM14, 40RUM16 and 40RUM28) are securely fastened to the solid steel fan shaft with split collets and clamp locking devices. Smaller unit sizes have spider-type bearings.

Controls for performance dependability

The 38AUM condensing units offer operating controls and components designed for performance dependability. The high efficiency hermetic scroll compressor is engineered for long life and durability. The compressors include vibration isolation for quiet operation. The high-pressure switch protects the entire refrigeration system from abnormally high operating pressures. A low-pressure switch protects the system from loss of charge. These units also include anti-short-cycling protection, which helps to protect the units against compressor failure.

All units include a crankcase heater to eliminate liquid slugging at start-up. Each unit comes standard with the Comfort Alert control system. This provides:

- System Go LED indicator
- Fault LED indicator
- Compressor fault LED indicator
- Phase loss protection
- Phase reversal protection
- Safety pressure indicator
- Anti-short cycle protection

Indoor-Air Quality (IAQ) features

The unique combination of IAQ features in the 40RUM Series air handlers help to ensure that only clean, fresh, conditioned air is delivered to the occupied space. Direct-expansion (DX) 4 row cooling coils prevent the build-up of humidity in the room, even during part-load conditions.

Standard 1-in (25.4mm) aluminum filters remove dust and airborne particles from the occupied space for cleaner air. The pitched, non-corroding drain pan can be adjusted for a right-hand or left-hand connection to suit many applications and provide positive drainage and prevent standing condensate.

Economy

The 40RUM Series packaged air handlers provide reduced installation expense and energy-efficient performance.

Quick installation is ensured by the multi-poise design. Units can be installed in either the horizontal or vertical configuration without modifications. Fan motors and contactors are pre-wired and thermostatic expansion valves (TXVs) are factory-installed on all 40RUM models.

High efficiency, precision-balanced fans minimize air turbulence, surging, and unbalanced operation, cutting operation expenses.

Coil flexibility

Model 40RUM direct-expansion coils have galvanized steel casings; inlet and outlet connections are on the same end. The coils are designed for use with Puron (R-410A) refrigerant and have 3/8-in. diameter copper tubes mechanically bonded to aluminum sine-wave fins. The coils include matched, factory-installed thermostatic expansion valves (TXVs) with matching distributor nozzles and offers a removable power element and extended connections.

Easier installation and service

The multi-poise design and component layout ensures quick unit installation and operation. Units can be converted from horizontal to vertical operation by simply repositioning the unit. Drain pan connections are duplicated on both sides of the unit. The filters, motor, drive, TXVs, and coil connections are all easily accessed by removing a single side panel.

MODEL NUMBER NOMENCLATURE - 40RUM- R410A SERIES

1	2	3	4	5	6	7	8	9	10	11	12	13	14	15	16	17	18
4	0	R	U	M	-	0	7	A	2	A	1	-	0	A	0	A	0

Model Type
40RUM = Commercial Packaged Air Handler

Refig. System Options
— = Direct Expansion

Unit Size
07 - 6.0 Ton
08 - 7.5 Ton
12 - 10 Ton
14 - 12.5 Ton
16 - 15.0 Ton
28 - 28.0 Ton

Factory Assigned
A = Default

Power Supply (V/Ph/Hz)
2 = 400/3/60
5 = 230/3/60
6 = 460/3/60

Indoor Fan Options
1 = Standard Static Option
2 = Medium Static Option
3 = High Static Option

Indoor Coil Options
A = Al/Cu
F = Cu/Cu

Panel Option
0 = Standard

Design Review
- = Factory Assigned

Type of Coil
A = Standard 4 Row

Service Options
0 = None

Electrical Options
A = None

Brand/Packaging
0 = Standard

AHRI CAPACITY RATING

Unit	Cooling Stages	Compressors	Unit Size (Ton)	Net Cooling Capacity (BTU/Hr)	Total Power (kW)	EER
38AUMZ07 / 40RUM07	1	1	6.0	69000	6.0	11.50
38AUMZ08 / 40RUM08	1	1	7.5	93000	8.3	11.20
38AUMD12 / 40RUM12	2	2	10.0	120000	10.4	11.50
38AUMD14 / 40RUM14	2	2	12.5	148000	13.5	11.00
38AUMD16 / 40RUM16	2	2	15.0	188000	16.9	11.10
38AUMD28 / 40RUM28	2	2	28.0	312000	29.2	10.70

Legend:

AHRI - Air Conditioning, Heating and Refrigeration Institute
 EER - Energy Efficiency Ratio

Notes:

1. Rated in accordance with AHRI Standards 340/360 and SASO 2874/2016
2. Ratings are net values, reflecting the effects of circulating fan heat
3. Rating are based on: Cooling Standard: 80 F db, 67 wb indoor entering-air temperature and 95 F db air entering outdoor unit

SOUND POWER LEVELS, dB

Unit	Indoor Sound (dB)							
	A-Weighted	63	125	250	500	1000	2000	4000
40RUM07	86.3	93.2	89.2	85.2	84.2	80.2	78.2	74.2
40RUM08	88.3	95.3	91.3	87.3	86.3	82.3	80.3	76.3
40RUM12	91.6	98.6	94.6	90.6	89.6	85.6	83.6	79.6
40RUM14	91.1	97.3	93.3	89.3	90.3	84.3	82.3	78.3
40RUM16	92.7	98.9	94.9	90.9	91.9	85.9	83.9	79.9
40RUM28	96.4	102.6	98.6	94.6	95.6	89.6	87.6	83.6

Legend:

dB - Decibel

ASHRAE - American Society of Heating, Refrigerating and Air Conditioning, Inc.

Notes:

1. The above estimated sound power levels are based upon the ASHRAE calculation approach from the ASHRAE 1987 HVAC Systems and Applications handbook, Chapter 52.
2. Since this data is calculated, these sound power levels may be different than the actual sound power levels.
3. The acoustic center of the unit is located at the geometric center of the unit.

UNIT PHYSICAL DATA (ENGLISH UNITS)

Unit 40RUM	07	08	12	14	16	28
Unit Size (Ton)	6.0	7.5	10.0	12.5	15.0	28.0
Operating Weight (lb)						
Base Unit with TXV (4 Rows)	399	404	425	695	713	1050
Plenum	175			225		325
Fans						
Qty / Diameter (in)	1 / 15			2 / 15		2 / 18
Nominal Airflow (cfm)	2400	3000	4000	5000	6000	10,000
Airflow Range (cfm)	1800-3000	2250-3750	3000-5000	3750-6250	4500-7500	7,500-12,500
Nominal Motor HP (Std. Motor)						
230V-3Ph-60Hz	2.4			2.9	3.7	10.0
400V-3Ph-60Hz	1.7				3.0	10.0
460V-3Ph-60Hz	2.4			2.9	3.7	-
Motor Speed (rpm)						
230/400/460V-3Ph-60Hz	1725					1745
Refrigerant	Puron® (R-410A)					
Operating Charge (lb)						
230V-3Ph-60Hz	13.7	16.1	9.5 / 10.6	14.0 / 15.0	19.3 / 22.0	13.40 / 12.10
400V-3Ph-60Hz	16.1	15.2	9.0 / 10.6	19.3 / 22.0	14.1 / 15.0	11.90 / 11.40
460V-3Ph-60Hz	14.7	15.1	9.9 / 10.6	14.0 / 14.9	19.3 / 21.9	-
Initial Charge (lb)						
230V-3Ph-60Hz	8.2	9.65	5.7 / 6.36	8.4 / 9.0	11.6 / 13.2	8.04 / 7.26
400V-3Ph-60Hz	9.7	9.1	5.4 / 6.35	11.7 / 13.2	8.4 / 9.0	7.14 / 6.84
460V-3Ph-60Hz	8.82	9.06	5.9 / 6.3	8.4 / 8.9	11.6 / 13.1	-
Piping Connections						
Coil Connection Type	TXV					
Suction line - Qty. / Size (in)	1 / 7/8		2 / 7/8		2 / 1 / 3/8	
Liquid line - Qty. / Size (in)	1 / 3/8	1 / 1/2	2 / 3/8		2 / 1/2	2 / 1/2
Filters	Washable - Aluminum					
Qty. / Size (HxWxD) (in)	4 / 16x20x1			8 / 16x20x1		4 / 20x20x1 4 / 20x25x1
Direct Expansion Coils	Enhanced Copper Tubes, Aluminum Double Wavy Fins					
Face Area (sq ft)	6.67	8.33	10.01	13.25	17.67	24.81
Max Working Pressure (psig)	650					
Fins / Inch	15					
No. of Rows	4					

UNIT PHYSICAL DATA (SI UNITS)

Unit 40RUM	07	08	12	14	16	28
Unit Size (Ton)	6.0	7.5	10.0	12.5	15.0	28.0
Operating Weight (kg)						
Base Unit with TXV (4 Rows)	181	183	193	315	323	470
Plenum	80			102		148
Fans						
Qty / Diameter (mm)	1 / 381			2 / 381		2 / 457
Nominal Airflow (L/s)	1133	1604	1888	2360	2831	4719
Airflow Range (L/s)	850-1416	1203-2006	1416-2360	1770-2949	2124-3539	3540-5900
Nominal Motor kW (Std. Motor)						
230V-3Ph-60Hz	1.8			2.2	2.8	7.5
400V-3Ph-60Hz	1.3	1.8		2.2	7.5	
460V-3Ph-60Hz	1.8			2.2	2.8	-
Motor Speed (r/s)						
230/400/460V-3Ph-60Hz	28.75					29.08
Refrigerant						
Puron (R-410A)						
Operating Charge (kg)						
230V-3Ph-60Hz	6.2	7.29	4.32 / 4.83	6.39 / 6.79	8.76 / 10.0	6.0 / 5.5
400V-3Ph-60Hz	7.3	6.88	4.1 / 4.8	8.76 / 9.96	6.39 / 6.79	5.4 / 5.1
460V-3Ph-60Hz	6.7	6.88	4.5 / 4.8	6.39 / 6.79	8.76 / 9.96	-
Initial Charge (kg)						
230V-3Ph-60Hz	3.72	4.4	2.6 / 2.9	3.8 / 4.1	5.25 / 6.0	3.8 / 3.3
400V-3Ph-60Hz	4.38	4.13	2.46 / 2.88	5.3 / 6.0	3.8 / 4.1	3.2 / 3.1
460V-3Ph-60Hz	4.02	4.13	2.7 / 2.88	3.84 / 4.08	5.26 / 5.96	-
Piping Connections						
Coil Connection Type						
TXV						
Suction line - Qty. / Size (mm)	1 / 22		2 / 22			2 / 25.4/9.5
Liquid line - Qty. / Size (mm)	1 / 9.5	1 / 12.7	2 / 9.5		2 / 12.7	2 / 12.7
Filters						
Washable - Aluminum						
Qty. / Size (HxWxD) (mm)	4 / 406x508x25.4			8 / 406x508x25.4		4 / 508x508x25.4 4 / 508x635x25.4
Direct Expansion Coil						
Enhanced Copper Tubes, Aluminum Double Wavy Fins						
Face Area (sq m)	0.62	0.77	0.93	1.23	1.64	2.39
Max Working Pressure (kPag)	4481					
Fins / Meter	591					
No. of Rows	4					

OPTIONS AND ACCESSORIES

Item	Option*	Accessory♦
Alternate Fan Motors	X	
Alternate Drives	X	
Condensate Drain Trap		X
Discharge Plenum		X
Electric Heater		X
Overhead Suspension Package		X
Programmable Thermostats		X
Return Air Grille		X
Sub-base		X
UV-C Germicidal Lamp**		X

* Factory-installed option.

♦ Field-installed accessory.

** Contact application engineer

40RUM Factory-Installed Options

Coil Description	Environment		
	Std Non-Corrosive	Moderate Coastal	Severe Coastal
Al Fins / Cu Tube	X		
Cu Fins / Cu Tube		X	X

40RUM factory-installed options

Alternate fan motors and drives are available to provide the widest possible range of performance.

40RUM field-installed accessories

Discharge plenum directs the air discharge into the occupied space; integral horizontal and vertical louvers enable redirection of airflow. This accessory is available unpainted or painted.

Return-air grille provides a protective barrier over the return-air opening and gives a finished appearance to units installed in the occupied space. This accessory is available unpainted or painted.

Sub-base provides a stable, raised platform and room for condensate drain connection for floor-mounted units. This accessory is available unpainted or painted.

Overhead suspension package includes necessary brackets to support units in horizontal installations.

Condensate drain trap includes an overflow shutoff switch that can be wired to turn off the unit if the trap becomes plugged. The kit also includes a wire harness that can be connected to an alarm if desired. The transparent trap is designed for easy service and maintenance.

Electric resistance heat coils have an open-wire design and are mounted in a rigid frame. Safety cutouts for high temperature conditions are standard. Terminal block for single-point power connections is included.

OPTIONS AND ACCESSORIES (cont.)

UV-C germicidal lamps inhibit the growth of mold and fungus, which may grow on evaporator coil and condensate pan surfaces. The use of UV-C germicidal lamps reduces the foul odors that may result from this growth of mold and fungus. It also provides a self-cleaning function for the evaporator coil and drain pan.

Carrier's line of thermostat provides both programmable and non-programmable capability with the new Debonair® line of commercial programmable thermostats. The TEMP System controls offer communication capability with staged heating and cooling, and the Commercial Electronic thermostats provide 7-day programmable capability for economical applications.

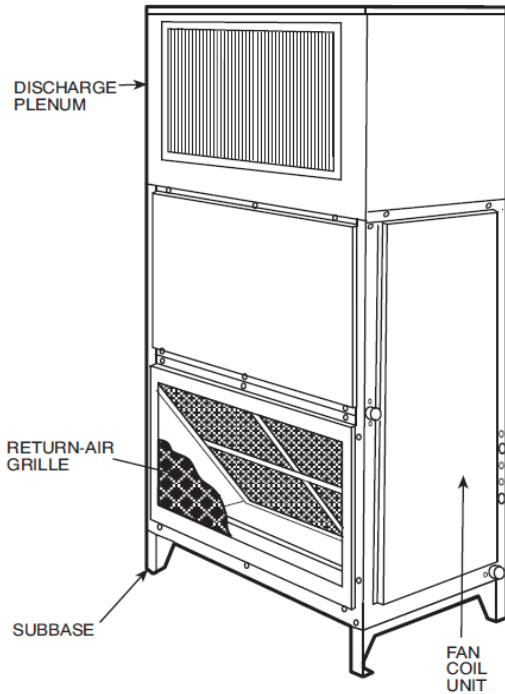

40RUM WITH DISCHARGE PLENUM
GRILLE AND SUBBASE

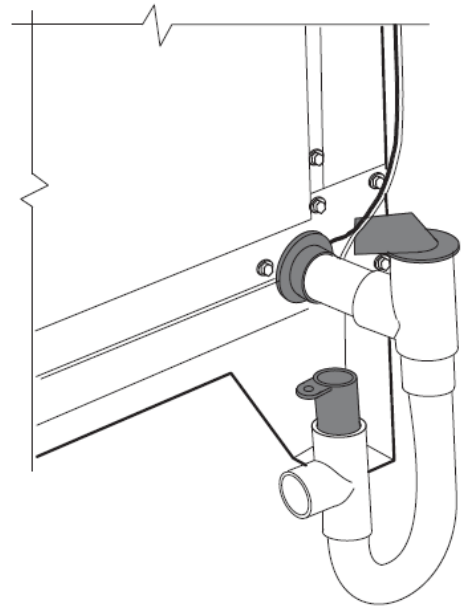

40RUM WITH CONDENSATE TRAP

BASE UNIT DIMENSIONS – 40RUM Series Size 07-12

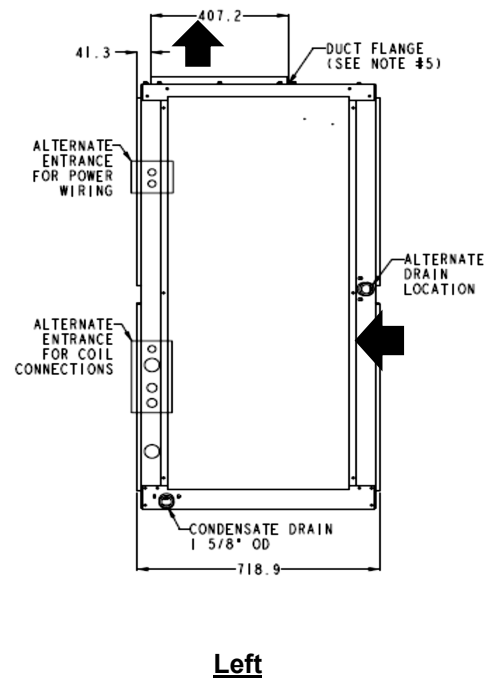
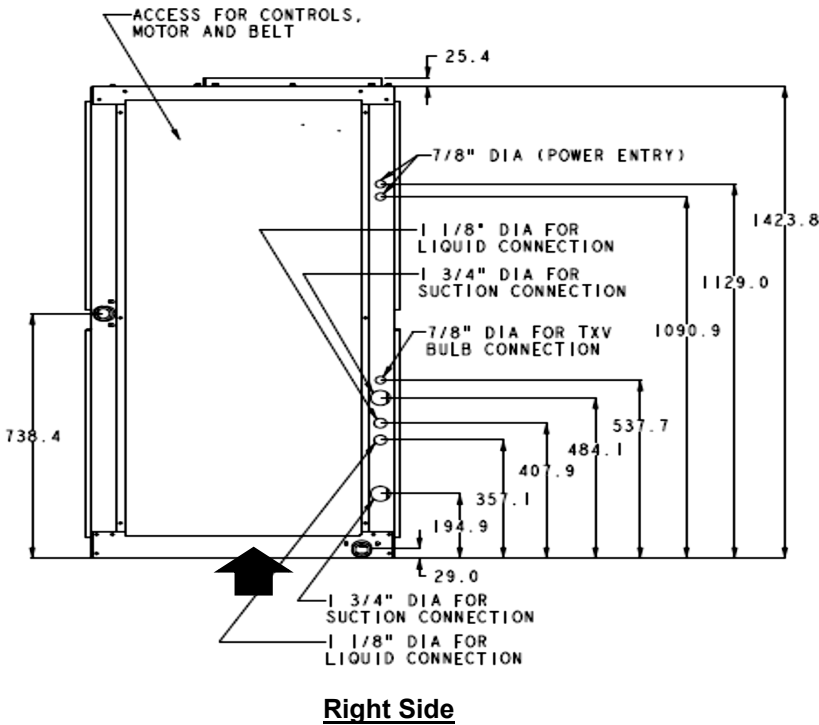
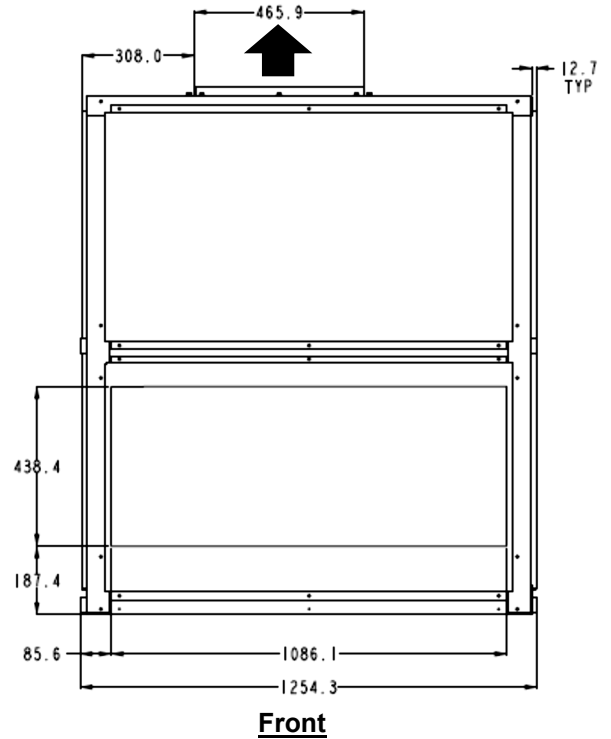
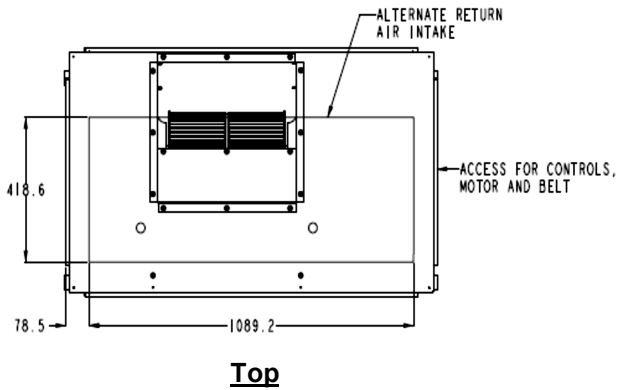

Notes:

1. Dimensions are in millimeter (mm).
2. Direction of airflow.
3. Recommended clearance:
 - Rear: 3.0 in (76.2mm), (2.0ft 6.0in (762mm) with electric heat accessory)
 - Front: 2.0ft 6.0in (762mm)
 - Right Side: 2.0ft 6.0in (762mm)
 - Left Side: 2.0ft 6.0in (762mm)
 - Local codes or jurisdiction may prevail.
4. Liquid piping not supplied by Carrier.
5. Duct flange is factory installed.

BASE UNIT DIMENSIONS – 40RUM Series Size 14 - 16

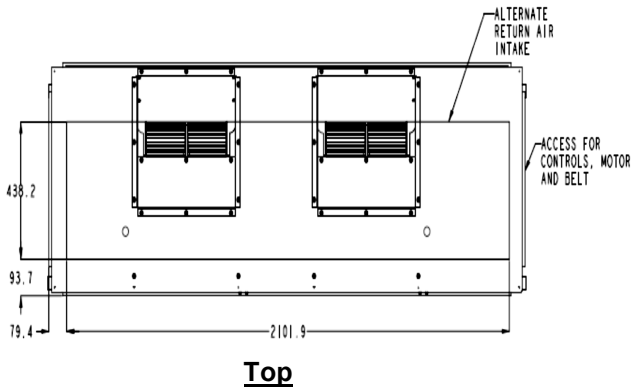

Top

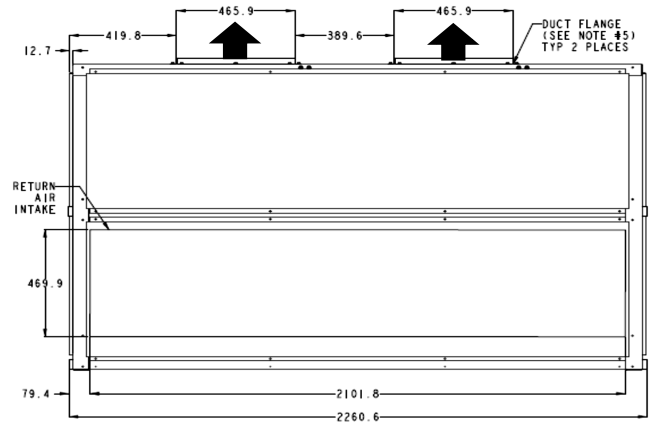

Front

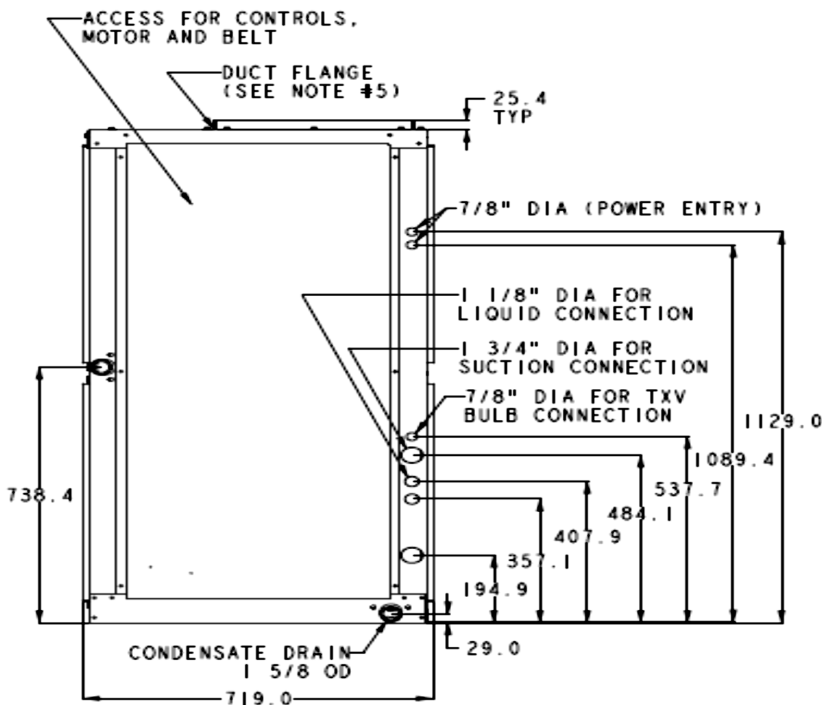

Right Side

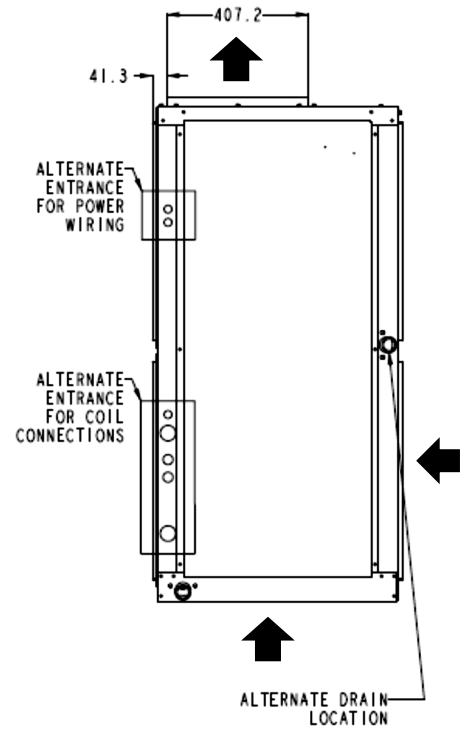

Left Side

Notes:

1. Dimensions are in millimeter (mm).
2. Direction of airflow.
3. Recommended clearance:
 - Rear: 3.0 in (76.2mm), (2.0ft 6.0in (762mm) with electric heat accessory)
 - Front: 2.0ft 6.0in (762mm)
 - Right Side: 2.0ft 6.0in (762mm)
 - Left Side: 2.0ft 6.0in (762mm)
 - Local codes or jurisdiction may prevail.
4. Liquid piping not supplied by Carrier.
5. Duct flange is factory installed.

DIMENSIONS – CORNER WEIGHTS

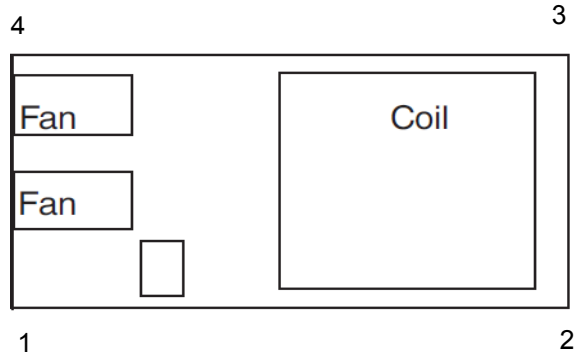

CORNER WEIGHTS - HORIZONTAL POSITION

40RUM - SI

40RUM UNIT SIZE	UNIT OR ACCESSORY NAME	UNIT OR ACCESSORY WEIGHT - (kg)	Corner Number (Weight In kg)			
			1	2	3	4
07	Fan Coil Base Unit	181	49.6	48.1	41.1	42.3
08	Fan Coil Base Unit	183	50.1	48.6	41.5	42.8
12	Fan Coil Base Unit	193	52.9	51.3	43.8	45.2
14	Fan Coil Base Unit	315	86.3	83.7	71.5	73.7
16	Fan Coil Base Unit	323	88.5	85.9	73.3	75.6
28	Fan Coil Base Unit	477	130.5	126.7	108.2	111.6

40RUM - English

40RUM UNIT SIZE	UNIT OR ACCESSORY NAME	UNIT OR ACCESSORY WEIGHT - (lb)	Corner Number (Weight In lb)			
			1	2	3	4
07	Fan Coil Base Unit	399	109.3	106.1	90.6	93.4
08	Fan Coil Base Unit	404	110.7	107.5	91.7	94.5
12	Fan Coil Base Unit	425	116.4	113	96.5	99.4
14	Fan Coil Base Unit	695	224	177.7	129.8	163.7
16	Fan Coil Base Unit	713	229.8	182.3	133.2	167.9
28	Fan Coil Base Unit	1050	338.4	268.5	196.1	247.2

CORNER WEIGHTS – VERTICAL POSITION

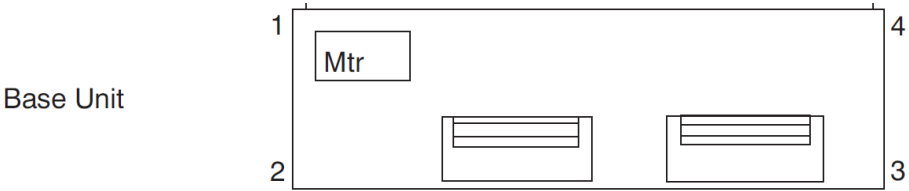

Note: Plenum is on top of positions 1,2,3,4

40RUM - SI

40RUM UNIT SIZE	UNIT OR ACCESSORY NAME	UNIT OR ACCESSORY WEIGHT (kg)	Corner Number (Weight In kg)			
			1	2	3	4
07	Fan Coil Base Unit	181	45.5	52.3	44.4	38.8
08	Fan Coil Base Unit	183	46.0	52.7	44.9	39.4
12	Fan Coil Base Unit	193	48.5	55.6	47.4	41.5
07 - 12	Plenum Add	80	23.3	16.8	16.8	23.3
14	Fan Coil Base Unit	315	86.6	95.5	69.8	63.3
16	Fan Coil Base Unit	323	88.9	97.9	71.6	64.9
14 - 16	Plenum Add	102	32.9	18.1	18.1	32.9
28	Fan Coil Base Unit	477	131.2	144.5	105.5	95.6
28	Plenum Add	148	43.1	31.1	31.1	43.1

40RUM - English

40RUM UNIT SIZE	UNIT OR ACCESSORY NAME		UNIT OR ACCESSORY WEIGHT (lb)	Corner Number (Weight In lb)			
				1	2	3	4
07	Fan Coil Base Unit		399	100.5	114.9	98	85.8
08	Fan Coil Base Unit		404	101.7	116.3	99.1	86.9
12	Fan Coil Base Unit		425	107.6	122.3	108	87.1
07 - 12	Plenum	Add	175	50.8	36.7	36.7	5.8
14	Fan Coil Base Unit		695	191.2	210.5	153.8	139.5
16	Fan Coil Base Unit		713	196.2	216	157.8	143.1
14 - 16	Plenum	Add	225	72.5	40	40	72.5
28	Fan Coil Base Unit		1050	288.9	318.1	232.3	210.6
28	Plenum	Add	325	94.5	68.3	68.3	94.5

ACCESSORY DIMENSIONS

Overhead Suspension Accessory

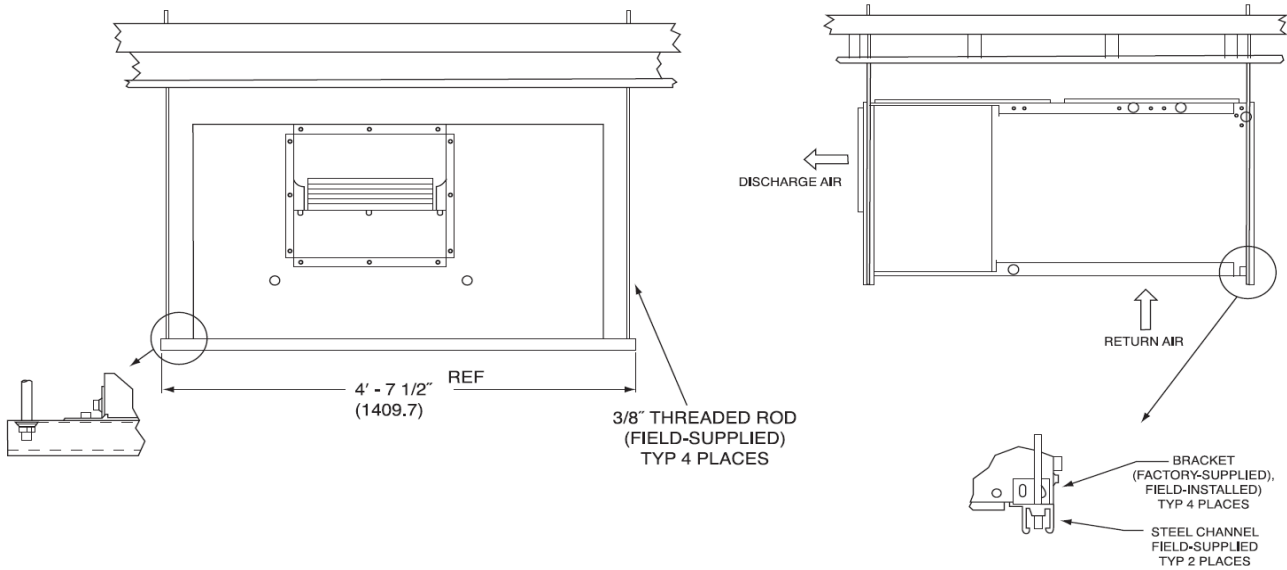

Unit Sizes 07-12 (FRONT)

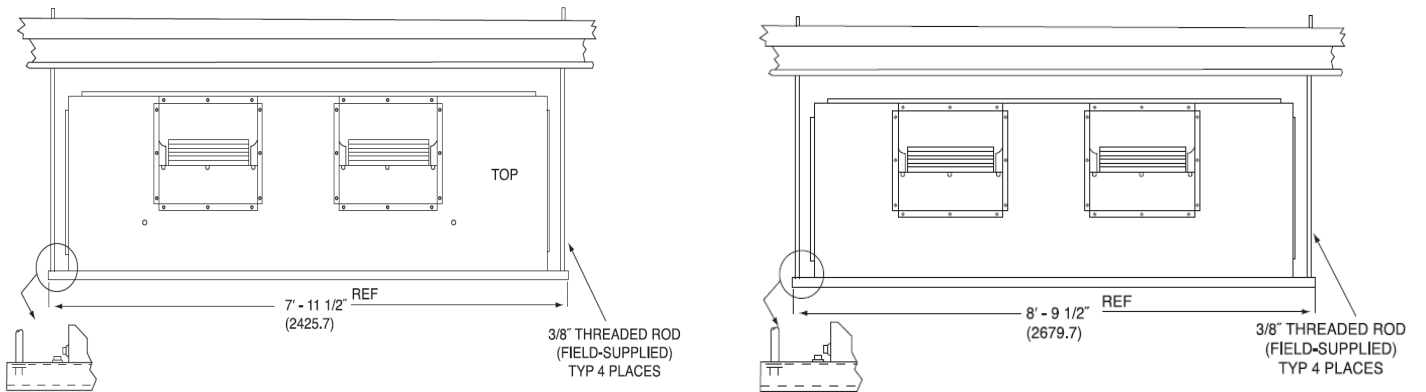

Unit Sizes 14-16 (FRONT)

Unit Sizes 28 (FRONT)

Note: Dimensions in () are millimeters.

ACCESSORY DIMENSIONS (cont.)

Plenum, Return-Air Grille, and Subbase Accessories

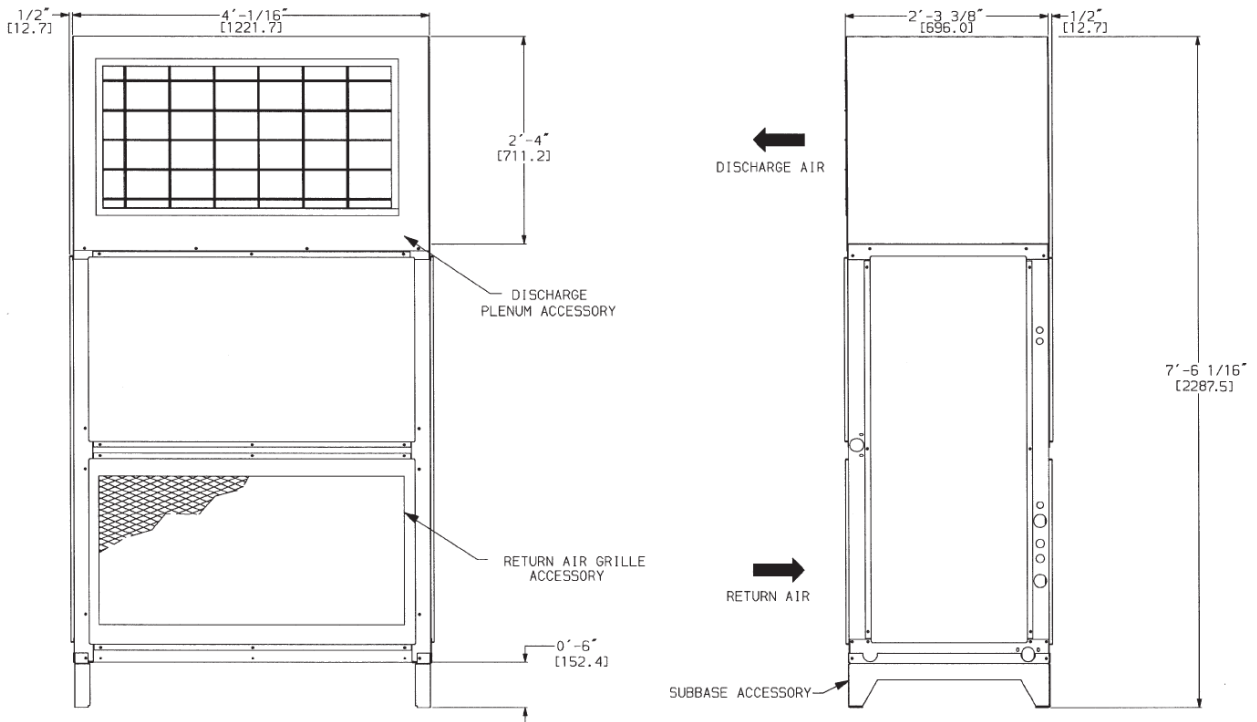

Unit Sizes 07-12

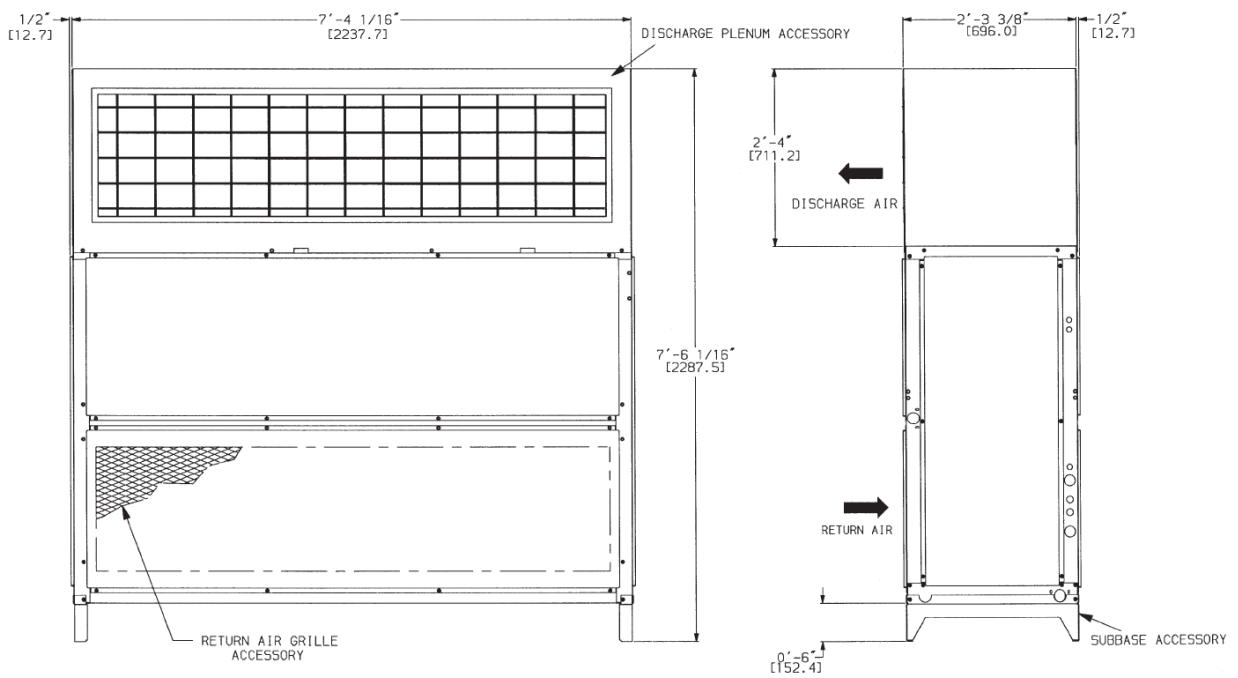

Unit Sizes 14-16

Note: Dimensions in [] are millimeters.

ACCESSORY DIMENSIONS (cont.)

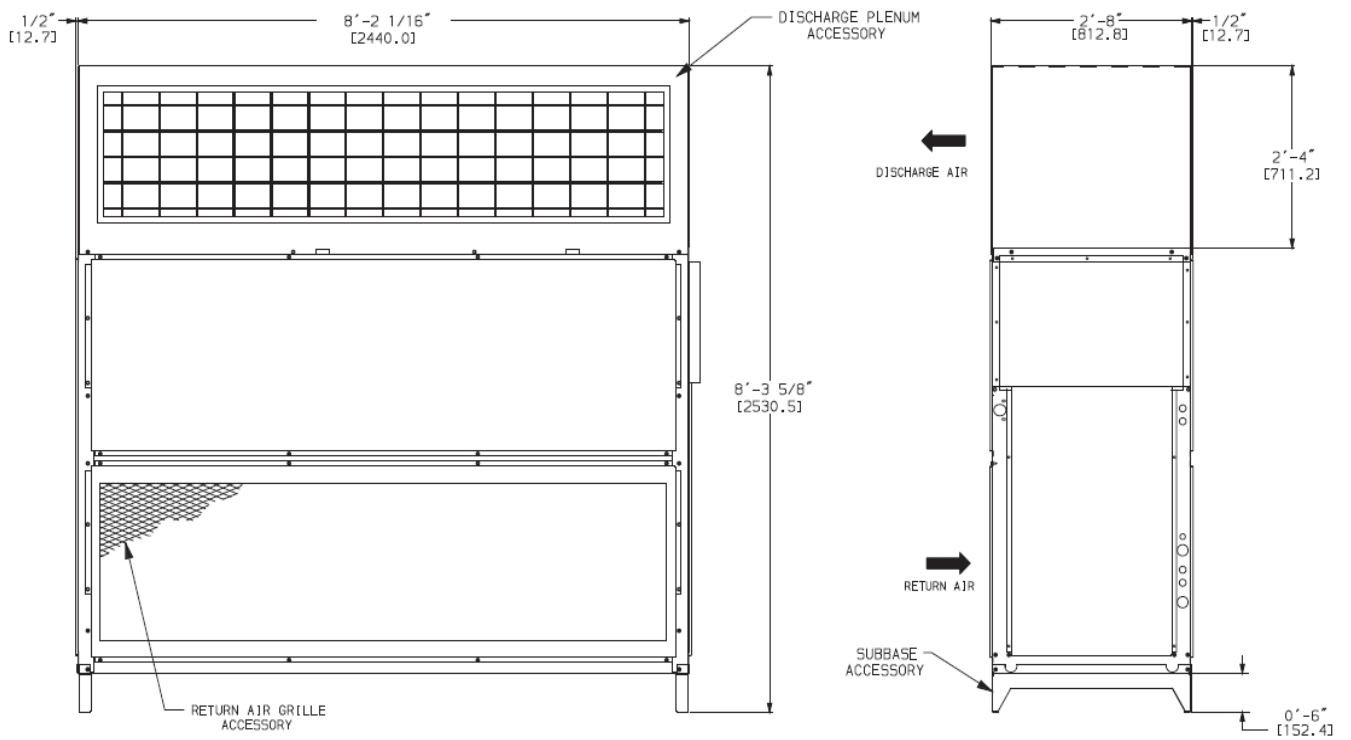

Unit Sizes 28

Note: Dimensions in [] are millimeters.

Electric Heat Accessory

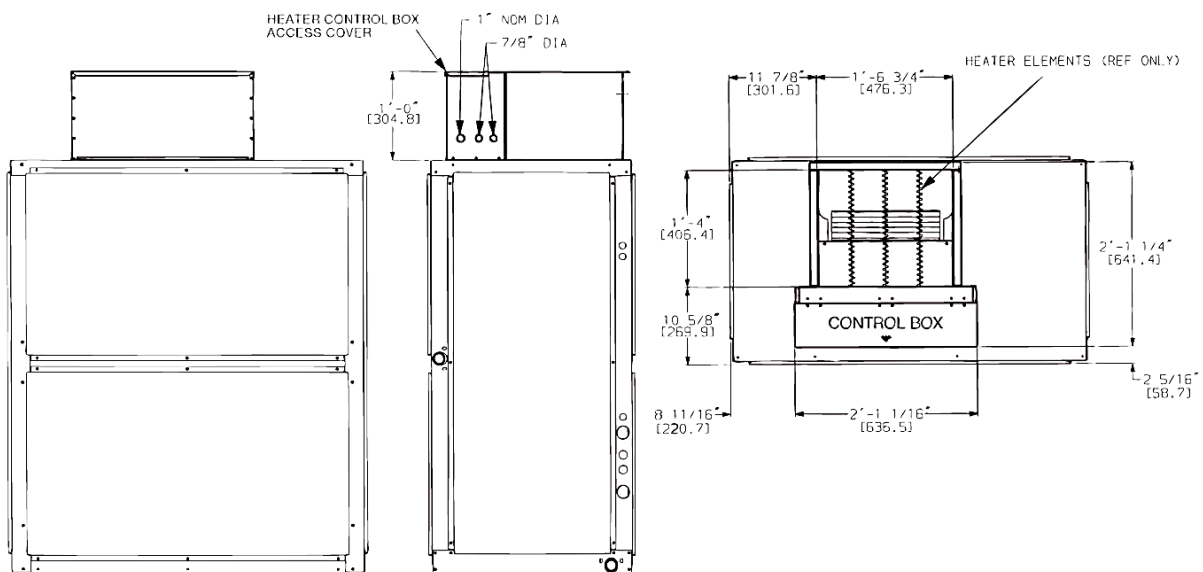

Unit Sizes 07-12

ACCESSORY DIMENSIONS (cont.)

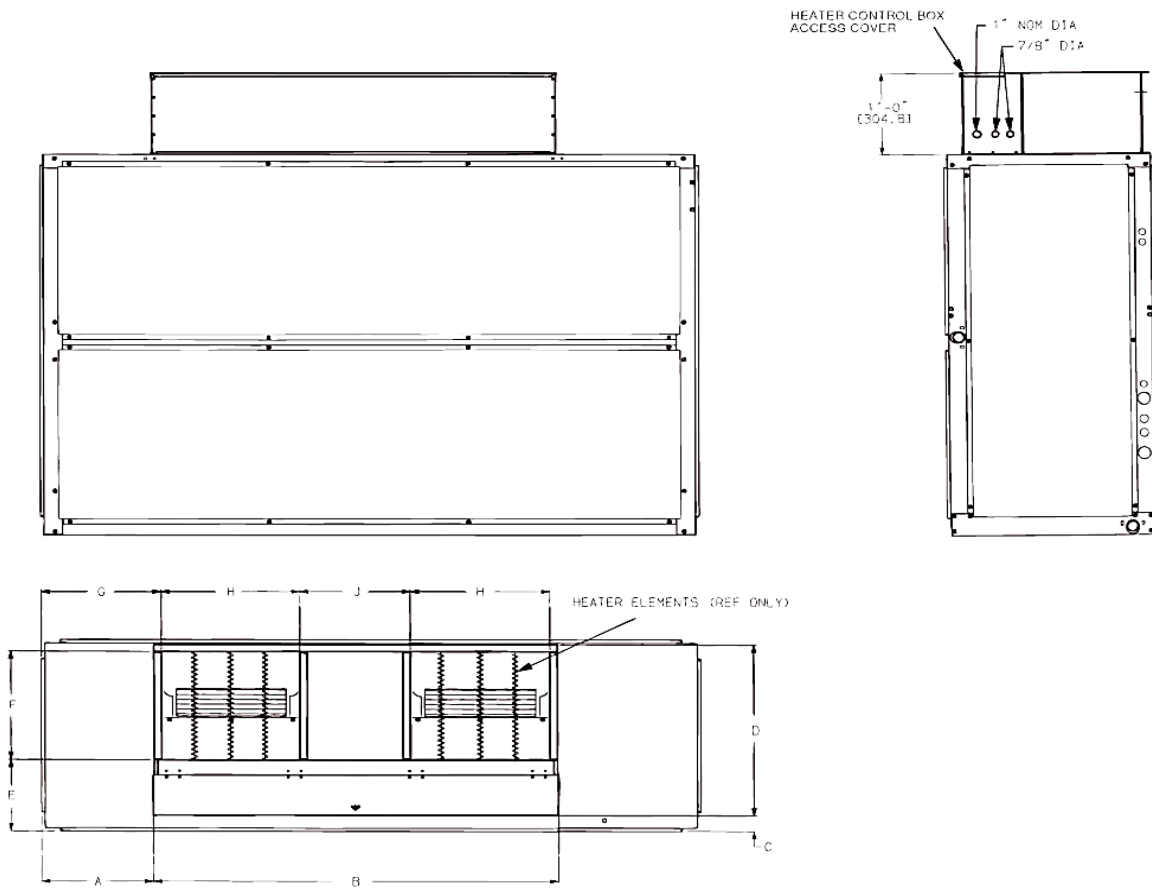

Unit Sizes 14-16

40RUM UNIT SIZE	A	B	C	D	E	F	G	H	J
14 - 16	1' - 3 1/4" [387.4]	4' - 6 3/8" [1381.1]	2 - 5/16" [58.7]	2' - 1 1/4" [641.4]	10' 5/8" [269.9]	1' - 4" [406.4]	1' - 4 5/16" [414.3]	1' - 6 3/4" [476.3]	1' - 7/8" [327.0]
28	1' - 3 3/8" [390.5]	5' - 4 7/8" [1636.8]	2' - 1/16" [26.9]	2' - 6 3/16" [766.8]	1' 1/4" [311.2]	1' - 7" [482.6]	1' - 4 5/16" [414.3]	1' - 10" [558.8]	1' - 4 7/16" [417.1]

Note: Dimensions in [] are millimeters.

SELECTION PROCEDURE

Combination ratings for 38AUMZ/D units matched with 40RUM Series air handlers are in this book. If unit is used with an air handler, use the Carrier Electronic Catalog selection program to obtain combined ratings.

I. Determine cooling load, evaporator-air temperature, and quantity.

Given:

Total Cooling Capacity - Required (TC)	121,000 Btuh
Sensible Heat Capacity - Required (SHC)	95,000 Btuh
Compressor - Type	Scroll
Temperature Air Entering - Condenser (Edb)	95°F
Temperature Air Entering - Evaporator (db/wb)	80°F db, 67°F wb
Evaporator Air Quantity	4,000 cfm
External Static Pressure	0.4 in. wg
Length of Interconnecting - Refrigerant Piping	25 ft (Linear)
Power Supply (V-Ph-Hz)	400-3-60

II. Select condensing unit air-handler combination.

For this example, select a 38AUMD12 matched with a 40RUM12 coil. This 38AUMD12/40RUM12 condensing unit air-handler combination provides 122,000 Btuh of total cooling capacity and 97,200 Btuh of sensible capacity at the given conditions. If other temperatures or airflow values are required, interpolate the values from the combination ratings.

III. Determine sizes of liquid and suction lines.

Enter Refrigerant Piping Sizes table. The sizes shown are based on an equivalent length of pipe. This equivalent length is equal to the linear length of pipe indicated at the top of each sizing column, plus a 50% allowance for fitting losses. (For a more accurate determination of actual equivalent length in place of using the estimated 50% value, refer to Carrier System Design Manual.) For this example, note in the linear length column that the proper pipe size is 1/2 in. for the liquid line and 13/8 in. for the suction line.

For extended line lengths over 100 feet, contact your Carrier representative or application engineer.

IV. Determine fan rpm and bhp (brake horsepower).

Refer to the 40RUM Air Handler Catalog – Fan Performance table. Enter the Air Handler Fan Performance table at 40RUM12 at 4000 cfm and move to the External Static Pressure (ESP) column. Note that the conditions require 803 rpm at 1.77 bhp.

V. Determine motor and drive.

Enter the Fan Motor Data tables and find the standard motor for 40RUM12 unit rated at 2.4 Hp. Since the bhp required is 1.77, a standard motor satisfies the requirement and should be used. Next, find the type of drive that satisfies the 803 rpm requirement in the Drive Data tables. For the 40RUM12 unit, the Standard Drive table shows an rpm range of 666-863. Since the rpm required is 803, the drive satisfies the requirement and should be used.

CONTROLS

Operating sequences

When the wall thermostat calls for cooling, terminals G and Y1 are energized. As a result, the indoor fan contactor (IFC) and the compressor contactor (C1) are energized, causing the indoor fan motor (IFM), compressor #1, and outdoor fans (OFM) to start. The field-supplied and field-installed liquid line valve also opens, allowing the system to function in cooling mode.

If the unit has 2 stages of cooling, the wall thermostat will additionally energize Y2. The Y2 signal will energize compressor contactor #2 (C2), causing compressor #2 to start.

Regardless of the number of stages, the field-supplied liquid line valve shall open and the outdoor fan motors (OFM) runs continuously while unit is cooling.

When cooling demand decrease, the thermostat will de-energize Y2. Y2 signal will de-energize compressor contactor #2 (C2), causing compressor #2 to stop. When cooling demand has been satisfied, the thermostat will de-energize Y1, and G terminals. Y1 and G signal will de-energize compressor contactor #1 (C1), causing compressor #1 to stop. If the wall thermostat is set to continuous (CONT), the indoor fan motor will continue to operate. Otherwise, the indoor fan motor will stop.

The outdoor fan motors (OFM) will turn off and field-supplied liquid line valve shall close, minimizing the potential for refrigerant migration.

COOLING CAPACITIES - English

Unit 40RUM	Evaporator Air		Coil Refrigerant Temp (°F)									
	Airflow (Cfm) BPF	Ewb (°F)	30		35		40		45		50	
			TC	SHC	TC	SHC	TC	SHC	TC	SHC	TC	SHC
7	1,800	72	124	59	111	54	100	49	85	43	69	37
		67	103	65	91	60	79	54	65	48	50	43
	0.06	62	86	71	74	65	61	59	49	49	42	42
		72	145	70	130	64	116	58	98	51	80	45
	2,400	67	120	78	106	73	92	66	76	60	59	52
		62	101	87	87	80	72	72	60	60	50	50
3,000	72	161	78	145	73	128	66	109	60	89	52	
	67	134	91	120	83	103	76	86	70	65	61	
0.12	62	112	102	96	92	80	80	69	69	58	58	
	2,250	72	160	77	145	70	129	63	110	56	89	48
67		133	85	118	78	102	70	85	62	66	56	
0.06	62	111	92	97	85	79	77	63	63	55	55	
	72	188	90	168	83	150	76	127	68	105	59	
3,000	67	156	102	138	95	120	86	99	77	77	69	
	62	131	112	113	105	93	93	78	78	66	66	
0.10	72	208	102	187	95	167	87	141	78	116	68	
	67	175	118	156	108	133	99	111	90	86	80	
0.12	62	147	131	125	120	105	105	89	89	76	76	
	3,000	72	206	98	186	86	164	81	141	72	115	62
67		172	109	153	99	131	91	109	81	84	72	
0.05	62	143	118	124	109	102	99	83	83	70	70	
	72	238	115	215	106	191	97	163	86	133	76	
4,000	67	199	130	177	121	153	111	127	99	98	88	
	62	168	145	145	134	121	121	101	101	85	85	
0.07	72	263	130	237	120	211	110	180	99	147	86	
	67	221	149	197	140	170	128	141	116	109	104	
0.12	62	187	170	159	155	134	134	116	116	98	98	
	3,750	72	250	120	229	111	206	102	176	91	143	79
67		211	136	190	126	162	115	133	101	106	91	
0.06	62	173	149	153	138	128	125	106	106	90	90	
	72	291	142	263	131	236	121	202	109	163	95	
5,000	67	247	164	218	153	186	139	155	126	124	112	
	62	200	183	175	168	151	151	128	128	109	109	
6,250	72	319	159	289	148	258	137	222	125	180	110	
	67	272	186	235	173	206	163	172	147	134	131	
0.10	62	221	211	193	193	168	168	146	146	125	125	
	4,500	72	321	152	289	140	259	127	221	114	184	101
67		265	170	238	157	203	142	170	127	133	113	
0.03	62	218	185	192	172	160	157	132	132	112	112	
	6,000	72	364	178	333	165	299	152	254	135	204	118
67		314	206	277	190	236	174	198	156	156	140	
0.05	62	256	228	225	211	190	190	159	159	135	135	
	7,500	72	407	201	363	185	330	173	282	156	224	137
67		347	237	299	218	261	203	220	182	174	164	
0.08	62	286	264	248	245	214	214	183	183	155	155	
	72	325	147	298	134	266	121	231	107	193	92	
7,500	67	271	159	243	146	212	132	178	118	141	103	
	0.08	62	222	170	195	157	165	143	132	128	109	109
9,750		72	328	148	300	135	268	121	233	107	195	93
	67	274	161	245	147	214	133	179	119	142	104	
0.09	62	224	172	196	158	166	144	133	129	110	110	
	12,500	72	376	170	345	157	309	142	268	126	222	109
67		315	189	282	173	246	158	205	141	164	125	
0.10	62	258	204	226	189	191	173	154	153	130	130	

Legend:

BPF — Bypass Factor
Ewb — Entering Wet-Bulb

SHC — Sensible Heat Capacity (1000 Btuh) Gross
TC — Total Capacity (1000 Btuh) Gross

Notes:

- Direct interpolation is permissible. Do not extrapolate.
- The following formulas may be used.

$$t_{db} = t_{edb} - \frac{\text{sensible capacity (Btuh)}}{1.10 \times \text{cfm}}$$

tlwb = Wet-bulb temperature corresponding to enthalpy of air leaving evaporator coil (hlwb).

$$hlwb = h_{ewb} - \frac{\text{total capacity (Btuh)}}{4.5 \times \text{cfm}}$$

Where: hewb = Enthalpy of air entering evaporator coil.

- The SHC is based on 80 F edb temperature of air entering evaporator coil.
 - Below 80 F edb, subtract (corr factor x cfm) from SHC.
 - Above 80 F edb, add (corr factor x cfm) to SHC.

BF	ENTERING AIR DRY-BULB TEMP (F)					
	79	78	77	76	75	under 75
	81	82	83	84	85	over 85
Correction Factor						
0.05	1.04	2.07	3.11	4.14	5.18	Use formula shown below.*
0.10	0.98	1.96	2.94	3.92	4.90	
0.20	0.87	1.74	2.62	3.49	4.36	
0.30	0.76	1.53	2.29	3.05	3.82	

- Interpolation is permissible.

*Correction Factor = 1.10 x (1 - BF) x (edb - 80).

- Cooling capacities are gross and do not include deductions for indoor fan motor heat.

- Variable Air Volume units will operate down to 70 cfm/ton. Performance at 70 cfm/ton is limited to unloaded operation and may be additionally limited to edb and ewb conditions.

COOLING CAPACITIES - SI

Unit 40RUM	Evaporator Air		Coil Refrigerant Temp (°C)									
	Airflow (L/s) BPF	Ewb (°C)	-1		2		4		7		10	
			TC	SHC	TC	SHC	TC	SHC	TC	SHC	TC	SHC
7	850	22	36	17	33	16	29	14	25	13	20	11
		19	30	19	27	18	23	16	19	14	15	13
	0.06	17	25	21	22	19	18	17	14	14	12	12
		22	42	21	38	19	34	17	29	15	24	13
	1130	19	35	23	31	21	27	19	22	18	17	15
		17	29	25	25	24	21	21	18	18	15	15
1420	22	47	23	42	21	38	19	32	18	26	15	
		19	39	27	35	24	30	22	25	20	19	18
	0.12	17	33	30	28	27	24	24	20	20	17	17
		22	47	22	42	21	38	19	32	16	26	14
8	1060	19	39	25	35	23	30	21	25	18	19	16
		17	33	27	28	25	23	22	19	19	16	16
	0.06	22	55	26	49	24	44	22	37	20	31	17
		19	46	30	40	28	35	25	29	22	22	20
	1420	17	38	33	33	31	27	27	23	23	19	19
		22	61	30	55	28	49	25	41	23	34	20
1770	19	51	35	46	32	39	29	33	26	25	23	
		17	43	38	37	35	31	31	26	26	22	22
	0.12	22	60	29	54	25	48	24	41	21	34	18
		19	50	32	45	29	38	27	32	24	25	21
12	1420	17	42	35	36	32	30	29	24	24	21	21
		22	70	34	63	31	56	28	48	25	39	22
	1890	19	58	38	52	35	45	33	37	29	29	26
		17	49	43	43	39	35	35	30	30	25	25
	2360	22	77	38	69	35	62	32	53	29	43	25
		19	65	44	58	41	50	38	41	34	32	30
0.12	17	55	50	47	45	39	39	34	34	29	29	
		22	73	35	67	33	60	30	52	27	42	23
	1770	19	62	40	56	37	47	34	39	30	31	27
		17	51	44	45	40	38	37	31	31	26	26
14	2360	22	85	41	77	39	69	36	59	32	48	28
		19	72	48	64	45	55	41	45	37	36	33
	0.08	17	59	54	51	49	44	44	38	38	32	32
		22	93	47	85	43	76	40	65	37	53	32
2980	19	80	55	69	51	60	48	50	43	39	39	
		17	65	62	57	57	49	49	43	43	37	37
	0.10	22	94	45	85	41	76	37	65	33	54	30
		19	78	50	70	46	59	42	50	37	39	33
16	2120	17	64	54	56	50	47	46	39	39	33	33
		22	107	52	98	48	88	45	74	40	60	35
	2830	19	92	60	81	56	69	51	58	46	46	41
		17	75	67	66	62	56	56	47	47	40	40
	0.05	22	119	59	106	54	97	51	83	46	66	40
		19	102	69	88	64	76	59	64	53	51	48
0.08	17	84	77	73	72	63	63	54	54	45	45	
		22	162	63	147	134	56	49	43	41	89	33
	7,500	19	132	70	117	63	100	55	81	47	60	39
		17	105	76	90	69	73	61	55	53	42	42
28	9,750	22	73	64	148	135	57	49	43	41	90	33
		19	134	71	118	63	101	53	81	48	61	40
	0.09	17	106	77	91	70	74	62	56	53	43	43
		22	88	76	173	69	153	61	131	52	105	42
12,500	19	157	87	138	78	118	158	96	60	73	51	
	0.10	17	125	95	107	87	88	78	67	67	54	54

Legend:

BPF — Bypass Factor
Ewb — Entering Wet-Bulb

SHC — Sensible Heat Capacity (1000 Btuh) Gross
TC — Total Capacity (1000 Btuh) Gross

Notes:

- Direct interpolation is permissible. Do not extrapolate.
- The following formulas may be used.

$$t_{db} = t_{edb} - \frac{\text{sensible capacity (Btuh)}}{1.10 \times \text{cfm}}$$

tlwb = Wet-bulb temperature corresponding to enthalpy of air leaving evaporator coil (hlwb).

$$hlwb = h_{ewb} - \frac{\text{total capacity (Btuh)}}{4.5 \times \text{cfm}}$$

Where: hewb = Enthalpy of air entering evaporator coil.

- The SHC is based on 80 F edb temperature of air entering evaporator coil.
 - Below 80 F edb, subtract (corr factor x cfm) from SHC.
 - Above 80 F edb, add (corr factor x cfm) to SHC.

BF	ENTERING AIR DRY-BULB TEMP (F)					
	79	78	77	76	75	under 75
	81	82	83	84	85	over 85
	Correction Factor					
0.05	1.04	2.07	3.11	4.14	5.18	Use formula shown below.*
0.10	0.98	1.96	2.94	3.92	4.90	
0.20	0.87	1.74	2.62	3.49	4.36	
0.30	0.76	1.53	2.29	3.05	3.82	

- Interpolation is permissible.

*Correction Factor = 1.10 x (1 - BF) x (edb - 80).

- Cooling capacities are gross and do not include deductions for indoor fan motor heat.

- Variable Air Volume units will operate down to 70 cfm/ton. Performance at 70 cfm/ton is limited to unloaded operation and may be additionally limited to edb and ewb conditions.

FAN PERFORMANCE DATA - English

Unit 40RUM	Airflow (Cfm)	External Static Pressure (in. wg)											
		0.2		0.4		0.6		0.8		1.0		1.2	
		Rpm	Bhp	Rpm	Bhp	Rpm	Bhp	Rpm	Bhp	Rpm	Bhp	Rpm	Bhp
7	1,800	471	0.26	564	0.37	649	0.49	727	0.63	797	0.77	862	0.92
	2,100	519	0.37	602	0.49	<u>679</u>	<u>0.62</u>	<u>751</u>	<u>0.77</u>	<u>819</u>	<u>0.92</u>	<u>882</u>	<u>1.09</u>
	2,400	568	0.51	645	0.64	715	0.79	781	0.94	844	1.11	905	1.28
	2,700	619	0.69	<u>690</u>	<u>0.84</u>	<u>755</u>	<u>0.99</u>	<u>816</u>	<u>1.15</u>	<u>875</u>	<u>1.33</u>	<u>932</u>	<u>1.51</u>
	3,000	671	0.90	738	1.07	799	1.24	856	1.41	910	1.60	963	1.79
8	2,250	510	0.39	594	0.51	669	0.65	739	0.79	<u>806</u>	<u>0.95</u>	<u>870</u>	<u>1.12</u>
	2,600	561	0.55	640	0.70	709	0.84	<u>773</u>	<u>1.00</u>	<u>834</u>	<u>1.16</u>	<u>893</u>	<u>1.34</u>
	3,000	621	0.79	695	0.96	759	1.12	818	1.30	874	1.47	928	1.66
	3,400	683	1.09	<u>752</u>	<u>1.29</u>	<u>813</u>	<u>1.48</u>	<u>869</u>	<u>1.67</u>	<u>920</u>	<u>1.86</u>	<u>970</u>	<u>2.06</u>
	3,750	739	1.42	804	1.63	862	1.85	915	2.05	964	2.26	1011	2.48
12	3,000	592	0.73	670	0.90	737	1.06	<u>797</u>	<u>1.23</u>	<u>854</u>	<u>1.41</u>	<u>908</u>	<u>1.59</u>
	3,500	664	1.08	735	1.28	798	1.48	855	1.67	908	1.87	958	2.07
	4,000	738	1.54	803	1.77	862	2.00	<u>917</u>	<u>2.23</u>	<u>967</u>	<u>2.45</u>	<u>1014</u>	<u>2.67</u>
	4,500	815	2.12	873	2.39	929	2.65	980	2.90	1028	3.16	1073	3.41
	5,000	893	2.84	<u>946</u>	<u>3.14</u>	<u>997</u>	<u>3.43</u>	<u>1046</u>	<u>3.72</u>	<u>1092</u>	<u>4.00</u>	<u>1135</u>	<u>4.28</u>
14	3,750	467	0.55	567	0.83	649	1.12	721	1.41	788	1.72	851	2.05
	4,300	504	0.74	599	1.05	679	1.38	748	1.70	811	2.04	871	2.39
	5,000	556	1.06	641	1.39	718	1.76	<u>786</u>	<u>2.14</u>	<u>847</u>	<u>2.52</u>	<u>903</u>	<u>2.91</u>
	5,700	612	1.47	686	1.82	759	2.23	825	2.66	884	3.09	939	3.52
	6,250	657	1.87	725	2.24	<u>793</u>	<u>2.66</u>	<u>856</u>	<u>3.12</u>	<u>915</u>	<u>3.59</u>	<u>969</u>	<u>4.06</u>
16	4,500	483	0.72	576	1.01	660	1.35	732	1.69	797	2.03	856	2.38
	5,300	538	1.07	617	1.37	696	1.74	<u>767</u>	<u>2.13</u>	<u>830</u>	<u>2.53</u>	<u>888</u>	<u>2.94</u>
	6,000	590	1.48	659	1.79	730	2.17	798	2.59	860	3.04	918	3.49
	6,800	651	2.06	712	2.39	<u>774</u>	<u>2.78</u>	<u>836</u>	<u>3.22</u>	<u>896</u>	<u>3.71</u>	<u>952</u>	<u>4.21</u>
	7,500	706	2.69	<u>761</u>	<u>3.04</u>	<u>817</u>	<u>3.44</u>	<u>873</u>	<u>3.89</u>	<u>929</u>	<u>4.39</u>	<u>984</u>	<u>4.93</u>
28	7,500	590	2.80	660	3.20	725	3.70	785	4.20	840	4.80	890	5.5
	8,750	690	4.50	750	4.70	805	5.10	<u>860</u>	<u>5.60</u>	<u>910</u>	<u>6.10</u>	<u>960</u>	<u>6.7</u>
	10,000	710	5.50	765	6.10	820	6.60	870	7.10	920	7.70	970	8.3
	11,250	800	7.90	<u>840</u>	<u>8.40</u>	<u>890</u>	<u>9.00</u>	<u>930</u>	<u>9.50</u>	<u>975</u>	<u>10.10</u>	<u>1020</u>	<u>10.6</u>
	12,500	890	10.60	930	11.40	—	—	—	—	—	—	—	—

Unit 40RUM	Airflow (Cfm)	External Static Pressure (in. wg)											
		1.4		1.6		1.8		2.0		2.2		2.4	
		Rpm	Bhp	Rpm	Bhp	Rpm	Bhp	Rpm	Bhp	Rpm	Bhp	Rpm	Bhp
7	1,800	<u>921</u>	<u>1.07</u>	<u>975</u>	<u>1.23</u>	<u>1026</u>	<u>1.39</u>	<u>1074</u>	<u>1.55</u>	<u>1120</u>	<u>1.72</u>	<u>1164</u>	<u>1.90</u>
	2,100	942	1.26	997	1.43	1048	1.61	1097	1.79	1143	1.97	1186	2.16
	2,400	<u>963</u>	<u>1.47</u>	<u>1017</u>	<u>1.66</u>	<u>1069</u>	<u>1.85</u>	1118	2.05	1164	2.25	—	—
	2,700	987	1.71	1039	1.91	1090	2.12	1138	2.33	1185	2.55	—	—
	3,000	<u>1015</u>	<u>1.99</u>	<u>1065</u>	<u>2.20</u>	1113	2.42	1161	2.65	—	—	—	—
8	2,250	<u>930</u>	<u>1.29</u>	<u>986</u>	<u>1.47</u>	1039	1.65	1089	1.84	1136	2.03	<u>1181</u>	<u>2.22</u>
	2,600	950	1.53	1005	1.72	1057	1.92	1107	2.13	1154	2.33	—	—
	3,000	980	1.86	1031	2.06	1081	2.27	1129	2.49	1175	2.72	—	—
	3,400	1018	2.26	1065	2.48	1111	2.70	1156	2.93	—	—	—	—
	3,750	<u>1057</u>	<u>2.69</u>	<u>1101</u>	<u>2.92</u>	<u>1144</u>	<u>3.15</u>	<u>1186</u>	<u>3.39</u>	—	—	—	—
12	3,000	961	1.78	1012	1.98	1062	2.19	1111	2.41	1158	2.64	—	—
	3,500	1005	2.27	<u>1052</u>	<u>2.49</u>	1098	2.71	1142	2.94	1186	3.18	—	—
	4,000	1058	2.90	1101	3.13	1143	3.36	1184	3.60	—	—	—	—
	4,500	1116	3.66	<u>1157</u>	<u>3.91</u>	<u>1196</u>	<u>4.16</u>	—	—	—	—	—	—
	5,000	<u>1176</u>	<u>4.56</u>	—	—	—	—	—	—	—	—	—	—
14	3,750	912	2.39	971	2.76	1028	3.14	1083	3.54	1135	3.95	1185	4.36
	4,300	928	2.75	982	3.13	1036	3.53	1087	3.94	1138	4.37	1187	4.81
	5,000	956	3.30	1007	3.71	1056	4.13	1104	4.56	1151	5.00	1196	5.46
	5,700	990	3.96	1039	4.40	1086	4.85	1130	5.31	1174	5.78	—	—
	6,250	<u>1019</u>	<u>4.54</u>	<u>1067</u>	<u>5.02</u>	1112	5.50	1156	5.99	1198	6.49	—	—
16	4,500	912	2.75	967	3.12	1019	3.52	1070	3.92	1120	4.35	1168	4.79
	5,300	942	3.34	992	3.76	1041	4.18	1088	4.61	1134	5.06	1179	5.52
	6,000	971	3.95	1020	4.40	1067	4.86	1112	5.33	1156	5.81	1198	6.29
	6,800	1005	4.72	1054	5.23	1101	5.75	1145	6.27	1187	6.79	—	—
	7,500	<u>1036</u>	<u>5.48</u>	<u>1084</u>	<u>6.04</u>	<u>1131</u>	<u>6.61</u>	1174	7.17	—	—	—	—
28	7,500	<u>940</u>	<u>6.30</u>	990	7.10	—	—	—	—	—	—	—	—
	8,750	<u>1000</u>	<u>7.60</u>	<u>1040</u>	<u>8.10</u>	—	—	—	—	—	—	—	—
	10,000	<u>1010</u>	<u>8.80</u>	—	—	—	—	—	—	—	—	—	—
	11,250	—	—	—	—	—	—	—	—	—	—	—	—
	12,500	—	—	—	—	—	—	—	—	—	—	—	—

LEGEND

Bhp — Brake Horsepower Input to Fan

ESP — External Static Pressure

Bold indicates field-supplied drive or motor is required. Plain type indicates standard motor and standard drive.

Underline indicates a different motor and drive combination other than the standard motor and standard drive combination is required.

Refer to fan motor and drive tables to complete selection.

Maximum allowable fan speed is 1200 rpm for all sizes. Fan performance is based on deductions for wet coil, clean 1-in. filters, and unit casing. See table below for factory-supplied filter pressure drop.

FAN PERFORMANCE DATA (cont.) - SI

Unit 40RUM	Airflow (L/s)	External Static Pressure (Pa)											
		50		100		150		200		250		300	
		r/s	kW	r/s	kW	r/s	kW	r/s	kW	r/s	kW	r/s	kW
7	850	7.86	0.19	9.40	0.27	10.81	0.37	12.11	0.47	13.29	0.57	14.36	0.69
	990	8.64	0.27	10.03	0.36	<u>11.31</u>	<u>0.46</u>	<u>12.52</u>	<u>0.57</u>	<u>13.65</u>	<u>0.69</u>	<u>14.71</u>	<u>0.81</u>
	1130	9.46	0.38	10.75	0.48	11.91	0.59	13.01	0.70	14.07	0.83	15.08	0.96
	1270	10.31	0.51	<u>11.51</u>	<u>0.62</u>	<u>12.58</u>	<u>0.74</u>	<u>13.60</u>	<u>0.86</u>	<u>14.58</u>	<u>0.99</u>	<u>15.53</u>	<u>1.13</u>
	1420	11.18	0.67	<u>12.30</u>	<u>0.80</u>	<u>13.31</u>	<u>0.92</u>	<u>14.26</u>	<u>1.05</u>	<u>15.17</u>	<u>1.19</u>	<u>16.05</u>	<u>1.33</u>
8	1060	8.50	0.29	9.91	0.38	11.15	0.48	12.32	0.59	<u>13.44</u>	<u>0.71</u>	<u>14.50</u>	<u>0.83</u>
	1230	9.35	0.41	10.67	0.52	11.81	0.63	<u>12.88</u>	<u>0.74</u>	<u>13.90</u>	<u>0.87</u>	<u>14.89</u>	<u>1.00</u>
	1420	10.35	0.59	11.59	0.71	<u>12.66</u>	<u>0.84</u>	<u>13.64</u>	<u>0.97</u>	<u>14.57</u>	<u>1.10</u>	<u>15.47</u>	<u>1.24</u>
	1600	11.39	0.81	<u>12.54</u>	<u>0.96</u>	<u>13.55</u>	<u>1.10</u>	<u>14.48</u>	<u>1.24</u>	<u>15.34</u>	<u>1.39</u>	<u>16.17</u>	<u>1.53</u>
	1770	12.32	1.06	<u>13.40</u>	<u>1.22</u>	<u>14.37</u>	<u>1.38</u>	<u>15.25</u>	<u>1.53</u>	<u>16.07</u>	<u>1.69</u>	<u>16.86</u>	<u>1.85</u>
12	1420	9.86	0.54	11.17	0.67	12.28	0.79	<u>13.29</u>	<u>0.92</u>	<u>14.23</u>	<u>1.05</u>	<u>15.14</u>	<u>1.19</u>
	1650	11.06	0.80	12.25	0.96	13.31	1.10	<u>14.25</u>	<u>1.25</u>	<u>15.13</u>	<u>1.39</u>	<u>15.96</u>	<u>1.54</u>
	1890	12.31	1.15	13.38	1.32	14.37	1.49	<u>15.28</u>	<u>1.66</u>	<u>16.11</u>	<u>1.83</u>	<u>16.89</u>	<u>1.99</u>
	2120	13.59	1.58	<u>14.55</u>	<u>1.78</u>	<u>15.48</u>	<u>1.97</u>	<u>16.34</u>	<u>2.17</u>	<u>17.14</u>	<u>2.35</u>	<u>17.89</u>	<u>2.54</u>
	2360	<u>14.89</u>	<u>2.12</u>	<u>15.76</u>	<u>2.34</u>	<u>16.62</u>	<u>2.56</u>	<u>17.43</u>	<u>2.77</u>	<u>18.20</u>	<u>2.98</u>	<u>18.92</u>	<u>3.19</u>
14	1770	7.78	0.41	9.46	0.62	10.82	0.83	12.02	1.05	13.13	1.28	14.19	1.53
	2030	8.40	0.55	9.98	0.78	11.31	1.03	12.47	1.27	13.52	1.52	14.51	1.78
	2360	9.27	0.79	10.68	1.04	11.96	1.31	13.09	1.60	14.11	1.88	15.05	2.17
	2690	10.20	1.10	11.44	1.36	12.64	1.66	13.74	1.98	14.74	2.30	15.65	2.63
	2950	10.96	1.39	12.09	1.67	<u>13.21</u>	<u>1.98</u>	<u>14.27</u>	<u>2.33</u>	<u>15.25</u>	<u>2.68</u>	<u>16.15</u>	<u>3.03</u>
16	2120	8.05	0.54	9.60	0.75	11.00	1.00	12.21	1.26	13.28	1.51	14.27	1.78
	2500	8.97	0.80	10.29	1.02	11.59	1.30	<u>12.78</u>	<u>1.59</u>	<u>13.84</u>	<u>1.89</u>	<u>14.80</u>	<u>2.19</u>
	2830	9.83	1.10	10.99	1.33	12.16	1.62	13.29	1.93	14.34	2.27	15.30	2.60
	3210	10.85	1.54	11.87	1.78	12.90	2.07	<u>13.93</u>	<u>2.40</u>	<u>14.93</u>	<u>2.76</u>	<u>15.87</u>	<u>3.14</u>
	3540	11.77	2.01	<u>12.69</u>	<u>2.27</u>	<u>13.62</u>	<u>2.56</u>	<u>14.56</u>	<u>2.90</u>	<u>15.49</u>	<u>3.27</u>	<u>16.40</u>	<u>3.67</u>
28	3,540	30.86	2.09	34.52	2.39	37.92	2.76	41.06	3.13	43.93	3.58	46.55	4.10
	4,130	36.09	3.36	39.23	3.50	42.10	3.80	<u>44.98</u>	<u>4.18</u>	<u>47.59</u>	<u>4.55</u>	<u>50.21</u>	<u>5.00</u>
	4,720	37.13	4.10	40.01	4.55	42.89	4.92	45.50	5.29	48.12	5.74	50.73	6.19
	5,309	41.84	5.89	<u>43.93</u>	<u>6.26</u>	<u>46.55</u>	<u>6.71</u>	<u>48.64</u>	<u>7.08</u>	<u>50.99</u>	<u>7.53</u>	<u>53.35</u>	<u>7.90</u>
	5,900	46.55	7.90	48.64	8.50	—	—	—	—	—	—	—	—

Unit 40RUM	Airflow (L/s)	External Static Pressure (Pa)											
		350		400		450		500		550		600	
		r/s	kW	r/s	kW	r/s	kW	r/s	kW	r/s	kW	r/s	kW
7	850	<u>15.34</u>	<u>0.80</u>	<u>16.25</u>	<u>0.92</u>	17.1	1.03	17.9	1.16	18.66	1.28	19.39	1.41
	990	15.69	0.94	16.61	1.07	17.47	1.20	18.28	1.33	19.04	1.47	19.77	1.61
	1130	<u>16.04</u>	<u>1.09</u>	<u>16.95</u>	<u>1.23</u>	<u>17.81</u>	<u>1.38</u>	<u>18.63</u>	<u>1.53</u>	<u>19.4</u>	<u>1.67</u>	—	—
	1270	16.44	1.27	17.32	1.42	18.17	1.58	18.97	1.74	19.75	1.90	—	—
	1420	<u>16.91</u>	<u>1.49</u>	<u>17.75</u>	<u>1.64</u>	<u>18.56</u>	<u>1.81</u>	<u>19.34</u>	<u>1.97</u>	—	—	—	—
8	1060	15.5	0.96	<u>16.43</u>	1.10	17.31	1.23	18.14	1.37	18.93	1.51	<u>19.68</u>	<u>1.66</u>
	1230	15.84	1.14	16.75	1.28	17.62	1.43	18.45	1.58	19.24	1.74	—	—
	1420	<u>16.34</u>	<u>1.38</u>	17.19	1.54	18.01	1.70	18.81	1.86	19.59	2.03	—	—
	1600	16.97	1.69	17.76	1.85	18.52	2.02	19.27	2.19	—	—	—	—
	1770	<u>17.61</u>	<u>2.01</u>	<u>18.35</u>	<u>2.18</u>	<u>19.07</u>	<u>2.35</u>	<u>19.77</u>	<u>2.53</u>	—	—	—	—
12	1420	16.02	1.33	16.87	1.48	17.71	1.64	18.52	1.80	19.3	1.97	—	—
	1650	16.76	1.70	<u>17.53</u>	<u>1.85</u>	<u>18.29</u>	<u>2.02</u>	<u>19.04</u>	<u>2.19</u>	<u>19.77</u>	<u>2.37</u>	—	—
	1890	17.64	2.16	18.35	2.33	19.05	2.51	19.74	2.69	—	—	—	—
	2120	<u>18.6</u>	<u>2.73</u>	<u>19.28</u>	<u>2.91</u>	<u>19.93</u>	<u>3.10</u>	—	—	—	—	—	—
	2360	<u>19.61</u>	<u>3.40</u>	—	—	—	—	—	—	—	—	—	—
14	1770	15.21	1.78	16.19	2.06	17.13	2.34	18.04	2.64	18.91	2.94	19.75	3.25
	2030	15.46	2.05	<u>16.37</u>	<u>2.33</u>	<u>17.26</u>	<u>2.63</u>	<u>18.12</u>	<u>2.94</u>	18.96	3.26	19.78	3.59
	2360	15.94	2.46	16.78	2.77	17.6	3.08	18.4	3.40	19.18	3.73	19.94	4.07
	2690	16.51	2.95	<u>17.32</u>	<u>3.28</u>	<u>18.09</u>	<u>3.62</u>	<u>18.84</u>	<u>3.96</u>	<u>19.57</u>	<u>4.31</u>	—	—
	2950	16.99	3.39	17.78	3.74	18.54	4.10	19.26	4.47	19.96	4.84	—	—
16	2120	15.21	2.05	16.11	2.33	16.98	2.62	17.83	2.93	18.66	3.24	19.47	3.57
	2500	15.69	2.49	16.54	2.80	17.35	3.12	18.14	3.44	18.9	3.77	19.64	4.11
	2830	16.18	2.94	17.01	3.28	17.79	3.63	18.54	3.97	19.27	4.33	19.97	4.69
	3210	16.75	3.52	17.57	3.90	18.34	4.29	19.08	4.67	19.78	5.06	—	—
	3540	<u>17.26</u>	<u>4.09</u>	<u>18.07</u>	<u>4.50</u>	<u>18.84</u>	<u>4.93</u>	19.57	5.35	—	—	—	—
28	3,540	49.16	4.70	51.78	5.29	—	—	—	—	—	—	—	—
	4,130	<u>52.30</u>	<u>5.67</u>	54.39	6.04	—	—	—	—	—	—	—	—
	4,720	<u>52.82</u>	<u>6.56</u>	—	—	—	—	—	—	—	—	—	—
	5,309	—	—	—	—	—	—	—	—	—	—	—	—
	5,900	—	—	—	—	—	—	—	—	—	—	—	—

LEGEND

Bhp — Brake Horsepower Input to Fan

ESP — External Static Pressure

Bold indicates field-supplied drive or motor is required. Plain type indicates standard motor and standard drive.

Underline indicates a different motor and drive combination other than the standard motor and standard drive combination is required.

Refer to fan motor and drive tables to complete selection.

Maximum allowable fan speed is 20 r/s for all sizes. Fan performance is based on deductions for wet coil, clean 25.4-mm filters, and unit casing. See table below for factory-supplied filter pressure drop.

PERFORMANCE DATA

Factory-Supplied Filter Pressure Drop — English

Unit 40RUM	Airflow (Cfm)	Pressure Drop (in. wg)
7	1800	0.05
	2400	0.08
	3000	0.11
8	2250	0.07
	3000	0.11
	3750	0.15
12	3000	0.11
	4000	0.17
	5000	0.23
14	3750	0.06
	5000	0.10
	6250	0.13
16	4500	0.08
	6000	0.12
	7500	0.17
28	7500	0.15
	10000	0.22
	12500	0.30

Factory-Supplied Filter Pressure Drop — SI

Unit 40RUM	Airflow (L/s)	Pressure Drop (Pa)
7	850	13
	1150	20
	1450	28
8	1000	17
	1400	27
	1800	38
12	1450	28
	1900	42
	2350	56
14	1750	15
	2350	24
	2950	33
16	2100	20
	2800	30
	3500	42
28	3500	36
	4700	55
	5900	76

Accessory Plenum Air Throw Data — English (Ft)

Unit 40RUM	Airflow (Cfm)	Vane Deflection		
		Straight	21]°	45°
7	2400	39	33	24
8	3000	45	38	28
12	4000	55	46	33
14	5000	45	38	28
16	6000	50	43	31
28	10000	76	65	47

TERMINAL VELOCITY (Fpm)	THROW FACTOR
50	X 1.50
100	X 0.75
150	X 0.50

NOTE: Throw distances shown are for 75 fpm terminal velocity. Use the following multipliers to determine throw values for other terminal velocities.

Accessory Plenum Air Throw Data — SI (m)

Unit 40RUM	Airflow (L/s)	Vane Deflection		
		Straight	21]°	45°
7	1150	11.71	9.91	7.20
8	1400	13.87	11.71	8.63
12	1900	16.65	13.93	9.99
14	2350	13.77	11.63	8.57
16	2800	15.41	13.25	9.55
28	28	4700	23.26	19.89

TERMINAL VELOCITY (m/sec)	THROW FACTOR
0.254	X 1.50
0.508	X 0.75
0.762	X 0.50

NOTE: Throw distances shown are for 0.381 m/sec terminal velocity. Use the following multipliers to determine throw values for other terminal velocities.

Accessory Pressure Drop — English (in. wg)

Unit	Airflow (Cfm)	Discharge Plenum	Electric Heater	Return Air Grille
7	1800	0.06	0.04	0.01
	2400	0.10	0.06	0.01
	3000	0.14	0.10	0.02
8	2250	0.09	0.06	0.01
	3000	0.14	0.10	0.02
	3750	0.21	0.15	0.03
12	3000	0.14	0.10	0.02
	4000	0.22	0.17	0.04
	5000	0.32	0.26	0.06
14	3750	0.07	0.04	0.01
	5000	0.12	0.07	0.02
	6250	0.17	0.11	0.02
16	4500	0.10	0.06	0.01
	6000	0.16	0.10	0.02
	7500	0.23	0.15	0.03
28	7500	0.15	0.09	0.02
	10000	0.24	0.16	0.03
	12500	0.34	0.24	0.05

Accessory Pressure Drop — SI (Pa)

Unit	Airflow (L/s)	Discharge Plenum	Electric Heater	Return Air Grille
7	850	15	9	2
	1150	25	16	3
	1450	36	26	5
8	1000	20	12	2
	1400	34	24	5
	1800	51	39	8
12	1450	36	26	5
	1900	56	43	10
	2350	79	65	15
14	1750	18	10	2
	2350	29	17	5
	2950	43	26	5
16	2100	24	14	2
	2800	39	24	5
	3500	56	37	7
28	3500	37	22	5
	4700	59	39	7
	5900	86	60	12

ELECTRICAL DATA TABLE

Standard Motors

Unit	Voltage	Voltage Range	Fan Motor		Power Supply	
			HP (kW)	FLA	MCA	MOCP
40RUM-07	230-3-60	207-253	2.4 (1.8)	5.2	6.5	15
	400-3-60	360-440	1.7 (1.3)	2.8	3.5	15
	460-3-60	414-506	2.4 (1.8)	2.6	3.3	15
40RUM-08	230-3-60	207-253	2.4 (1.8)	5.2	6.5	15
	400-3-60	360-440	1.7 (1.3)	2.8	3.5	15
	460-3-60	414-506	2.4 (1.8)	2.6	3.3	15
40RUM-12	230-3-60	207-253	2.4 (1.8)	5.2	6.5	15
	400-3-60	360-440	2.4 (1.8)	4.1	5.1	15
	460-3-60	414-506	2.4 (1.8)	2.6	3.3	15
40RUM-14	230-3-60	207-253	2.9 (2.2)	7.5	9.4	15
	400-3-60	360-440	2.4 (1.8)	4.1	5.1	15
	460-3-60	414-506	2.9 (2.2)	3.8	4.8	15
40RUM-16	230-3-60	207-253	3.7 (2.8)	10.2	12.8	20
	400-3-60	360-440	3.0 (2.2)	5.0	6.3	15
	460-3-60	414-506	3.7 (2.8)	4.8	6.0	15
40RUM-28	230-3-60	207-253	10 (7.45)	25.2	31.5	50
	400-3-60	360-440	10 (7.45)	16.2	20.3	35

Alternate Motors

Unit	Voltage	Voltage Range	Fan Motor		Power Supply	
			HP (kW)	FLA	MCA	MOCP
40RUM-07	230-3-60	207-253	2.9 (2.2)	7.5	9.4	15
	400-3-60	360-440	2.4 (1.8)	4.1	5.1	15
	460-3-60	414-506	2.9 (2.2)	3.8	4.8	15
40RUM-08	230-3-60	207-253	2.9 (2.2)	7.5	9.4	15
	400-3-60	360-440	3.0 (2.2)	5.0	6.3	15
	460-3-60	414-506	2.9 (2.2)	3.8	4.8	15
40RUM-12	230-3-60	207-253	3.7 (2.8)	10.2	12.6	20
	400-3-60	360-440	4.7 (3.5)	7.5	9.4	15
	460-3-60	414-506	3.7 (2.8)	4.8	6.0	15
40RUM-14	230-3-60	207-253	3.7 (2.8)	10.2	12.6	20
	400-3-60	360-440	4.7 (3.5)	7.5	9.4	15
	460-3-60	414-506	3.7 (2.8)	4.8	6.0	15
40RUM-16	230-3-60	207-253	5.0 (3.7)	12.6	15.6	25
	400-3-60	360-440	4.7 (3.5)	7.5	9.4	15
	460-3-60	414-506	5.0 (3.7)	6.3	7.9	15
40RUM-28	230-3-60	207-253	10 (7.45)	25.2	31.5	50
	400-3-60	360-440	10 (7.45)	16.2	20.3	35

Legend and Notes for Electrical Data Table

FLA - Full Load Amps

HP - Horse Power

kW - Kilowatt

MCA - Minimum Circuit Amps

MOCP - Maximum Overcurrent Protection

Application heater kW (Using multiplication factor table in Electric Resistance Heater Data Table)

Unbalanced 3-Phase Supply Voltage

Never operate a motor where phase imbalance in supply voltage is greater than 2%.

Use the following formula to determine the percentage of voltage imbalance

$$= 100 \times \frac{\text{Maximum Deviation From Average Voltage}}{\text{Average Voltage}}$$

Example: Supply Voltage is 400V - 3ph - 60Hz

AB = 392v	Average Voltage = $\frac{392 + 404 + 395}{3}$
BC = 404v	
AC = 395v	= $\frac{1191}{3}$ = 397V

Determine maximum deviation from average voltage.

(AB) 397 - 392 = 5v

(BC) 404 - 397 = 7v

(AC) 457 - 397 = 2v

Maximum Deviation is 7v.

Determine Percentage Voltage Imbalance.

$$\% \text{ Voltage Imbalance} = 100 \times \frac{7}{397} = 1.76\%$$

This amount of phase imbalance is satisfactory as it is below the maximum allowable 2%

IMPORTANT: If the supply voltage phase imbalance is more than 2% contact your local electric utility company

ELECTRICAL HEATER DATA TABLE

Heater Part No. CAELHEAT	40RUM Size	V-Ph-Hz	Fan Motor			Electric Heater(s)					MCA	MOCP
			Hp	kW	FLA	Nominal Capacity (kW)	Application Capacity (kW)			FLA		
							Stage 1	Stage 2	Total			
001A00	07	230-3-60	2.4	1.80	5.2	5	4.6	—	4.6	11.6	21.0	25.0
			2.9	2.16	7.5	5	4.6	—	4.6	11.6	23.9	25.0
002A00		400-3-60	1.7	1.30	2.8	5	3.5	—	3.5	5.1	9.9	15.0
			2.4	1.80	4.1	5	3.5	—	3.5	5.1	11.5	15.0
002A00		460-3-60	2.4	1.80	2.6	5	4.6	—	4.6	5.8	10.5	15.0
			2.9	2.16	3.8	5	4.6	—	4.6	5.8	12.0	15.0
004A00		230-3-60	2.4	1.80	5.2	10	9.2	—	9.2	23.1	35.4	40.0
			2.9	2.16	7.5	10	9.2	—	9.2	23.1	38.3	40.0
005A00		400-3-60	1.7	1.30	2.8	10	6.9	—	6.9	10.1	16.1	20.0
			2.4	1.80	4.1	10	6.9	—	6.9	10.1	17.8	20.0
005A00		460-3-60	2.4	1.80	2.6	10	9.2	—	9.2	11.6	17.8	20.0
			2.9	2.16	3.8	10	9.2	—	9.2	11.6	19.3	20.0
007A00		230-3-60	2.4	1.80	5.2	15	13.8	—	13.8	34.6	49.8	50.0
			2.9	2.16	7.5	15	13.8	—	13.8	34.6	52.6	60.0
008A00		400-3-60	1.7	1.30	2.8	15	10.4	—	10.4	15.0	22.3	25.0
			2.4	1.80	4.1	15	10.4	—	10.4	15.0	23.9	25.0
008A00		460-3-60	2.4	1.80	2.6	15	13.8	—	13.8	17.3	24.9	25.0
			2.9	2.16	3.8	15	13.8	—	13.8	17.3	26.4	30.0
010A00		230-3-60	2.4	1.80	5.2	25	13.8	9.2	23.0	57.7	78.6	80.0
			2.9	2.16	7.5	25	13.8	9.2	23.0	57.7	81.5	90.0
011A00		400-3-60	1.7	1.30	2.8	25	10.4	6.9	17.3	25.0	34.8	40.0
			2.4	1.80	4.1	25	10.4	6.9	17.3	25.0	36.4	40.0
011A00		460-3-60	2.4	1.80	2.6	25	13.8	9.2	23.0	28.9	39.4	40.0
			2.9	2.16	3.8	25	13.8	9.2	23.0	28.9	40.9	50.0
001A00	08	230-3-60	2.4	1.80	5.2	5	4.6	—	4.6	11.6	21.0	25.0
			2.9	2.16	7.5	5	4.6	—	4.6	11.6	23.9	25.0
002A00		400-3-60	1.7	1.30	2.8	5	3.5	—	3.5	5.1	9.9	15.0
			3.0	2.20	5.0	5	3.5	—	3.5	5.1	12.6	15.0
002A00		460-3-60	2.4	1.80	2.6	5	4.6	—	4.6	5.8	10.5	15.0
			2.9	2.16	3.8	5	4.6	—	4.6	5.8	12.0	15.0
004A00		230-3-60	2.4	1.80	5.2	10	9.2	—	9.2	23.1	35.4	40.0
			2.9	2.16	7.5	10	9.2	—	9.2	23.1	38.3	40.0
005A00		400-3-60	1.7	1.30	2.8	10	6.9	—	6.9	10.1	16.1	20.0
			3.0	2.20	5.0	10	6.9	—	6.9	10.1	18.9	20.0
005A00		460-3-60	2.4	1.80	2.6	10	9.2	—	9.2	11.6	17.8	20.0
			2.9	2.16	3.8	10	9.2	—	9.2	11.6	19.3	20.0
007A00		230-3-60	2.4	1.80	5.2	15	13.8	—	13.8	34.6	49.8	50.0
			2.9	2.16	7.5	15	13.8	—	13.8	34.6	52.6	60.0
008A00		400-3-60	1.7	1.30	2.8	15	10.4	—	10.4	15.0	22.3	25.0
			3.0	2.20	5.0	15	10.4	—	10.4	15.0	25.0	25.0
008A00		460-3-60	2.4	1.80	2.6	15	13.8	—	13.8	17.3	24.9	25.0
			2.9	2.16	3.8	15	13.8	—	13.8	17.3	26.4	30.0
010A00		230-3-60	2.4	1.80	5.2	25	13.8	9.2	23.0	57.7	78.6	80.0
			2.9	2.16	7.5	25	13.8	9.2	23.0	57.7	81.5	80.0
011A00		400-3-60	1.7	1.30	2.8	25	10.4	6.9	17.3	25.0	34.8	40.0
			3.0	2.20	5.0	25	10.4	6.9	17.3	25.0	37.5	40.0
011A00		460-3-60	2.4	1.80	2.6	25	13.8	9.2	23.0	28.9	39.4	40.0
			2.9	2.16	3.8	25	13.8	9.2	23.0	28.9	40.9	45.0
013A00	230-3-60	2.4	1.80	5.2	35	18.4	13.8	32.2	80.8	107.5	110.0	
		2.9	2.16	7.5	35	18.4	13.8	32.2	80.8	110.4	120.0	
014A00	400-3-60	1.7	1.30	2.8	35	13.9	10.4	24.3	35.1	47.4	50.0	
		3.0	2.20	5.0	35	13.9	10.4	24.3	35.1	50.1	60.0	

Legend and Notes for Electrical Data Table

FLA - Full Load Amps

HP - Horse Power

kW - Kilowatt

MCA - Minimum Circuit Amps

MOCP - Maximum Overcurrent Protection

1. Heater contactor coils are 24 v and require 8 va holding current.

2. Electric heaters are tested and ETL approved at maximum total external static pressure of 1.9 in. wg.

3. MCA and MOCP values apply to both standard and alternate factory-supplied motors.

4. Approximate shipping weight for CAELHEAT001A00-015A00 is 55 lb (25 kg), and for CAELHEAT016A00-026A00 is 60 lb (27 kg) each



ELECTRICAL HEATER DATA TABLE (cont.)

Heater Part No. CAELHEAT	40RUM Size	V-Ph-Hz	Fan Motor			Electric Heater(s)					MCA	MOCP
			Hp	kW	FLA	Nominal Capacity (kW)	Application Capacity (kW)			FLA		
							Stage 1	Stage 2	Total			
001A00	12	230-3-60	2.4	1.80	5.2	5	4.6	—	4.6	11.6	21.0	25.0
			3.7	2.80	10.2	5	4.6	—	4.6	11.6	27.3	30.0
002A00		400-3-60	2.4	1.80	4.1	5	3.5	—	3.5	5.1	11.5	15.0
			4.7	3.50	7.5	5	3.5	—	3.5	5.1	15.8	20.0
002A00		460-3-60	2.4	1.80	2.6	5	4.6	—	4.6	5.8	10.5	15.0
			3.7	2.80	4.8	5	4.6	—	4.6	5.8	13.3	15.0
004A00		230-3-60	2.4	1.80	5.2	10	9.2	—	9.2	23.1	35.4	40.0
			3.7	2.20	10.2	10	9.2	—	9.2	23.1	41.6	45.0
005A00		400-3-60	2.4	1.80	4.1	10	6.9	—	6.9	10.1	17.8	20.0
			4.7	3.50	7.5	10	6.9	—	6.9	10.1	22.0	25.0
005A00		460-3-60	2.4	1.80	2.6	10	9.2	—	9.2	11.6	17.8	20.0
			3.7	2.80	4.8	10	9.2	—	9.2	11.6	20.5	25.0
007A00		230-3-60	2.4	1.80	5.2	15	13.8	—	13.8	34.6	49.8	50.0
			3.7	2.80	10.2	15	13.8	—	13.8	34.6	56.0	60.0
008A00		400-3-60	2.4	1.80	4.1	15	10.4	—	10.4	15.0	23.9	25.0
			4.7	3.50	7.5	15	10.4	—	10.4	15.0	28.1	30.0
008A00		460-3-60	2.4	1.80	2.6	15	13.8	—	13.8	17.3	24.9	25.0
			3.7	2.80	4.8	15	13.8	—	13.8	17.3	27.6	30.0
010A00		230-3-60	2.4	1.80	5.2	25	13.8	9.2	23.0	57.7	78.6	80.0
			3.7	2.80	10.2	25	13.8	9.2	23.0	57.7	84.9	90.0
011A00		400-3-60	2.4	1.80	4.1	25	10.4	6.9	17.3	25.0	36.4	40.0
			4.7	3.50	7.5	25	10.4	6.9	17.3	25.0	40.6	45.0
011A00		460-3-60	2.4	1.80	2.6	25	13.8	9.2	23.0	28.9	39.4	40.0
			3.7	2.80	4.8	25	13.8	9.2	23.0	28.9	42.1	45.0
013A00	230-3-60	2.4	1.80	5.2	35	18.4	13.8	32.2	80.8	107.5	110.0	
		3.7	2.80	10.2	35	18.4	13.8	32.2	80.8	113.8	115.0	
014A00	400-3-60	2.4	1.80	4.1	35	13.9	10.4	24.3	35.1	49.0	50.0	
		4.7	3.50	7.5	35	13.9	10.4	24.3	35.1	53.3	60.0	
016A00	14	230-3-60	2.9	2.20	7.5	10	9.2	—	9.2	23.1	38.3	40.0
			3.7	2.80	10.2	10	9.2	—	9.2	23.1	41.6	45.0
017A00		400-3-60	2.4	1.80	4.1	10	6.9	—	6.9	10.0	17.6	20.0
			4.7	3.50	7.5	10	6.9	—	6.9	10.0	21.9	25.0
017A00		460-3-60	2.9	2.16	3.8	10	9.2	—	9.2	11.6	19.3	20.0
			3.7	2.80	4.8	10	9.2	—	9.2	11.6	20.5	25.0
019A00		230-3-60	2.9	2.20	7.5	20	18.4	—	18.4	46.2	67.1	70.0
			3.7	2.80	10.2	20	18.4	—	18.4	46.2	70.5	80.0
020A00		400-3-60	2.4	1.80	4.1	20	13.9	—	13.9	20.1	30.3	35.0
			4.7	3.50	7.5	20	13.9	—	13.9	20.1	34.5	35.0
020A00		460-3-60	2.9	2.16	3.8	20	18.4	—	18.4	23.1	33.6	35.0
			3.7	2.80	4.8	20	18.4	—	18.4	23.1	34.9	35.0
022A00		230-3-60	2.9	2.20	7.5	30	18.4	9.2	27.6	69.3	96.0	100.0
			3.7	2.80	10.2	30	18.4	9.2	27.6	69.3	99.4	100.0
023A00		400-3-60	2.4	1.80	4.1	30	13.9	6.9	20.8	30.0	42.6	45.0
			4.7	3.50	7.5	30	13.9	6.9	20.8	30.0	46.9	50.0
023A00		460-3-60	2.9	2.16	3.8	30	18.4	9.2	27.6	34.6	48.0	50.0
			3.7	2.80	4.8	30	18.4	9.2	27.6	34.6	49.3	50.0

Legend and Notes for Electrical Data Table

FLA - Full Load Amps

HP - Horse Power

kW - Kilowatt

MCA - Minimum Circuit Amps

MOCP - Maximum Overcurrent Protection



1. Heater contactor coils are 24 v and require 8 va holding current.

2. Electric heaters are tested and ETL approved at maximum total external static pressure of 1.9 in. wg.

3. MCA and MOCP values apply to both standard and alternate factory-supplied motors.

4. Approximate shipping weight for CAELHEAT001A00-015A00 is 55 lb (25 kg), and for CAELHEAT016A00-026A00 is 60 lb (27 kg) each

ELECTRICAL HEATER DATA TABLE (cont.)

Heater Part No. CAELHEAT	40RUM Size	V-Ph-Hz	Fan Motor			Electric Heater(s)					MCA	MOCP
			Hp	kW	FLA	Nominal Capacity (kW)	Application Capacity (kW)			FLA		
							Stage 1	Stage 2	Total			
016A00	16	230-3-60	3.7	2.80	10.2	10	9.2	—	9.2	23.1	41.6	45.0
			5.0	3.70	12.6	10	9.2	—	9.2	23.1	44.6	50.0
017A00		400-3-60	3.0	2.20	5.0	10	6.9	—	6.9	10.0	18.8	20.0
			4.7	3.50	7.5	10	6.9	—	6.9	10.0	21.9	25.0
017A00		460-3-60	3.7	2.80	4.8	10	9.2	—	9.2	11.6	20.5	25.0
			5.0	3.70	6.3	10	9.2	—	9.2	11.6	22.4	25.0
019A00		230-3-60	3.7	2.80	10.2	20	18.4	—	18.4	46.2	70.5	80.0
			5.0	3.70	12.6	20	18.4	—	18.4	46.2	73.5	80.0
020A00		400-3-60	3.0	2.20	5.0	20	13.9	—	13.9	20.1	31.4	35.0
			4.7	3.50	7.5	20	13.9	—	13.9	20.1	34.5	35.0
020A00		460-3-60	3.7	2.80	4.8	20	18.4	—	18.4	23.1	34.9	35.0
			5.0	3.70	6.3	20	18.4	—	18.4	23.1	36.8	40.0
022A00		230-3-60	3.7	2.80	10.2	30	18.4	9.2	27.6	69.3	99.4	100.0
			5.0	3.70	12.6	30	18.4	9.2	27.6	69.3	102.4	110.0
023A00		400-3-60	3.0	2.20	5.0	30	13.9	6.9	20.8	30.0	43.8	45.0
			4.7	3.50	7.5	30	13.9	6.9	20.8	30.0	46.9	50.0
023A00		460-3-60	3.7	2.80	4.8	30	18.4	9.2	27.6	34.6	49.3	50.0
			5.0	3.70	6.3	30	18.4	9.2	27.6	34.6	51.1	60.0
025A00		230-3-60	3.7	2.80	10.2	50	27.5	18.4	45.9	115.2	156.8	160.0
			5.0	3.70	12.6	50	27.5	18.4	45.9	115.2	159.8	160.0
026A00		400-3-60	3.0	2.20	5.0	50	20.8	13.9	34.7	50.1	68.9	70.0
			4.7	3.50	7.5	50	20.8	13.9	34.7	50.1	72.0	80.0
026A00		460-3-60	3.7	2.80	4.8	50	27.5	18.4	45.9	57.6	78.0	80.0
			5.0	3.70	6.3	50	27.5	18.4	45.9	57.6	79.9	80.0
028A00	28	230-3-60	10.0	7.45	25.2	20	18.2	—	18.2	45.7	88.6	100.0
			10.0	7.45	25.2	20	18.2	—	18.2	45.7	88.6	100.0
029A00		400-3-60	10.0	7.45	16.2	20	13.9	—	13.9	20.1	45.4	50.0
			10.0	7.45	16.2	20	13.9	—	13.9	20.1	45.4	50.0
031A00		230-3-60	10.0	7.45	25.2	40	18.4	18.4	36.8	92.4	147.0	150.0
			10.0	7.45	25.2	40	18.4	18.4	36.8	92.4	147.0	150.0
032A00		400-3-60	10.0	7.45	16.2	40	13.9	13.9	27.8	40.1	70.4	80.0
			10.0	7.45	16.2	40	13.9	13.9	27.8	40.1	70.4	80.0

Legend and Notes for Electrical Data Table

FLA - Full Load Amps

HP - Horse Power

kW - Kilowatt

MCA - Minimum Circuit Amps

MOCP - Maximum Overcurrent Protection



1. Heater contactor coils are 24 v and require 8 va holding current.

2. Electric heaters are tested and ETL approved at maximum total external static pressure of 1.9 in. wg.

3. MCA and MOCP values apply to both standard and alternate factory-supplied motors.

4. Approximate shipping weight for CAELHEAT001A00-015A00 is 55 lb (25 kg), and for CAELHEAT016A00-026A00 is 60 lb (27 kg) each

TYPICAL WIRING SCHEMATIC

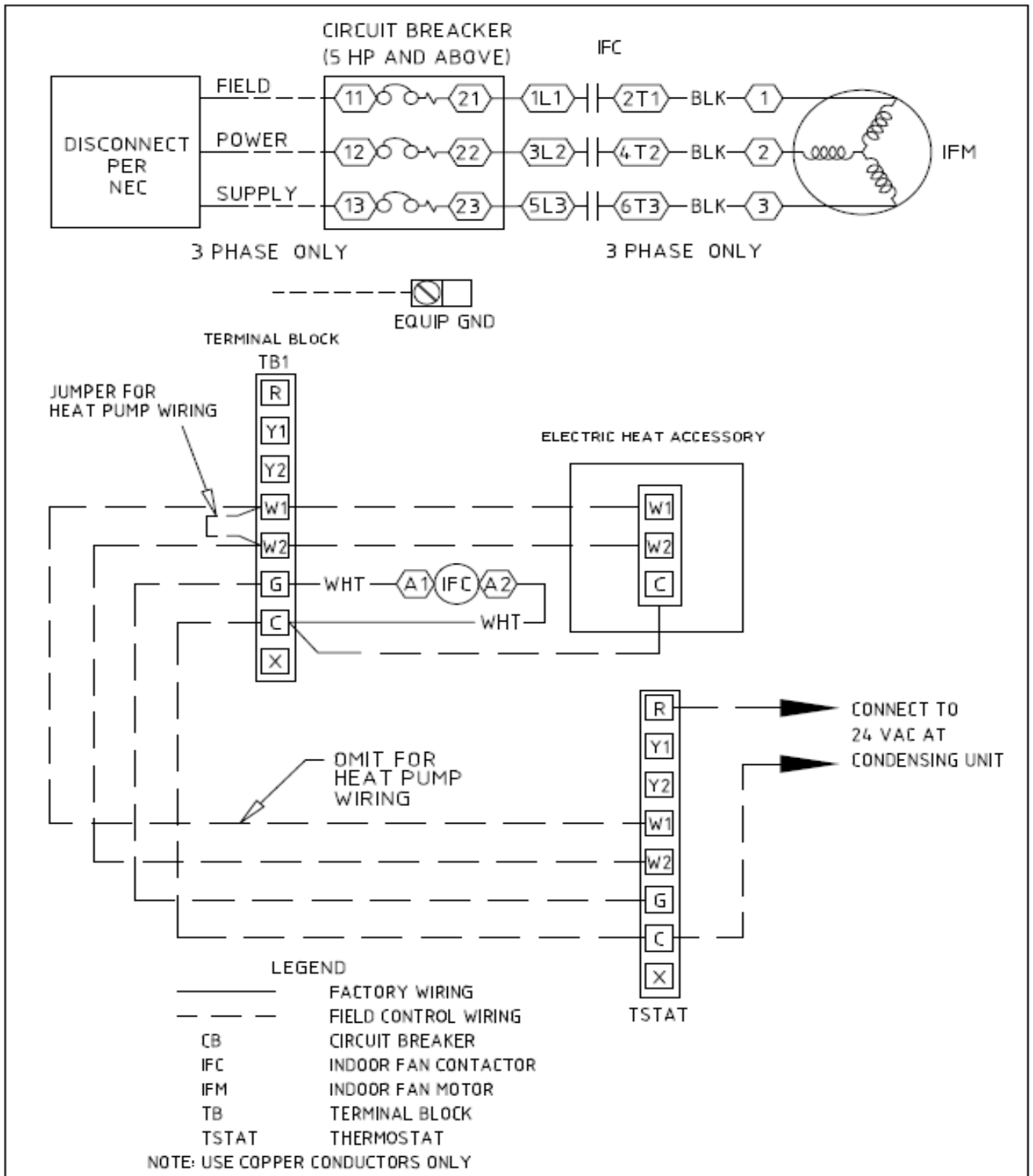

40RUM Unit Size 7 – 28

TYPICAL PIPING AND WIRING

Roof Installation and a Ceiling-Mounted Fan Coil

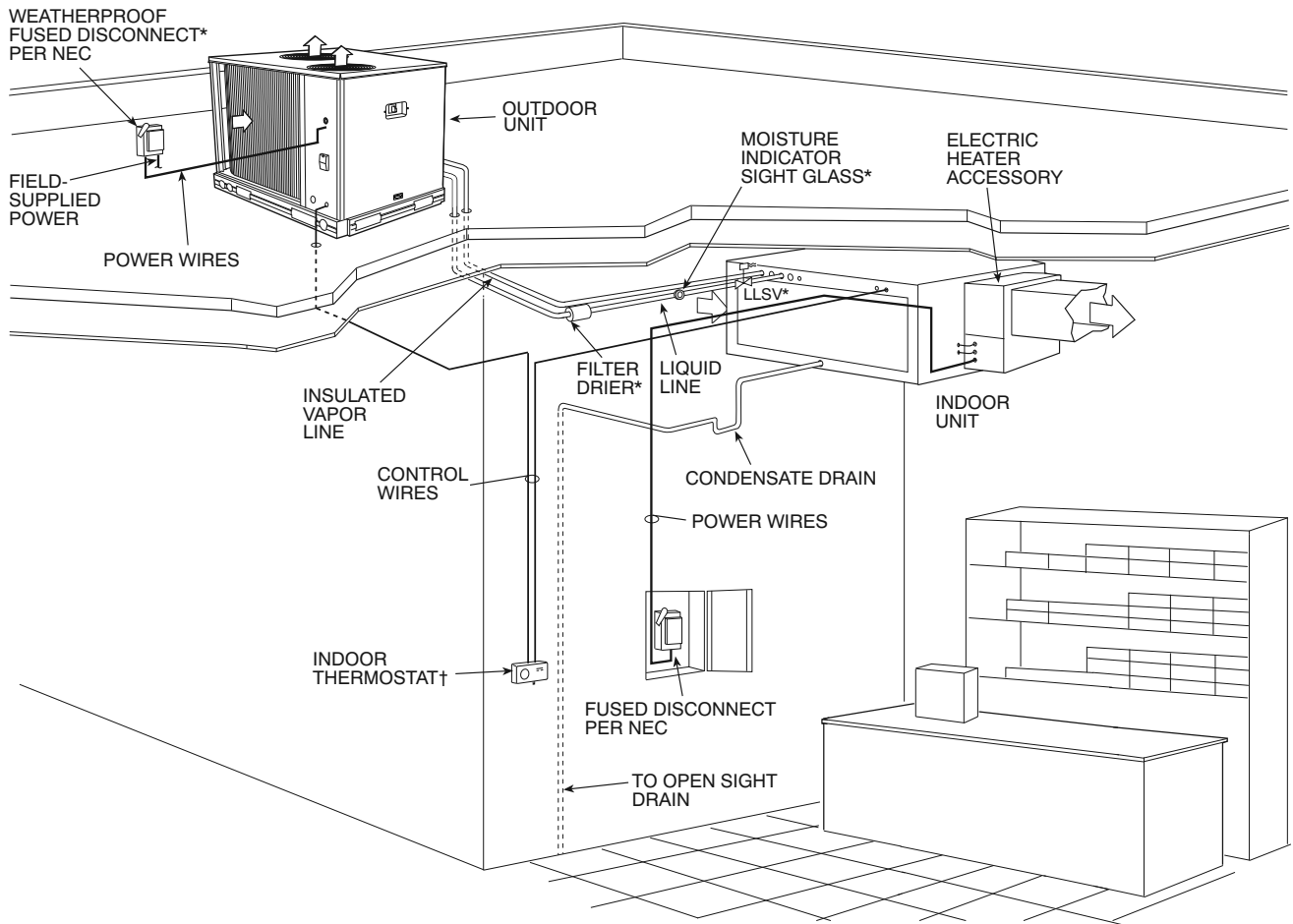

C09054

LEGEND:

NEC – National Electrical Code
 TXV – Thermostatic Expansion Valve

* Field-supplied

† Double riser may be required. Consult condensing unit product data catalog for details.

NOTES:

1. All piping must follow standard refrigerant piping techniques. Refer to Carrier System Design Manual for details.
2. All wiring must comply with the applicable local and national codes.
3. Wiring and piping shown are general points-of-connection guides only and are not intended for, or to include all details for, a specific installation.
4. Liquid line solenoid valve (solenoid drop control) is recommended to prevent refrigerant migration to the compressor.
5. Internal factory-supplied TXVs not shown.

TYPICAL PIPING AND WIRING (CONT.)

Roof Installation and a Vertical Discharge Fan Coil

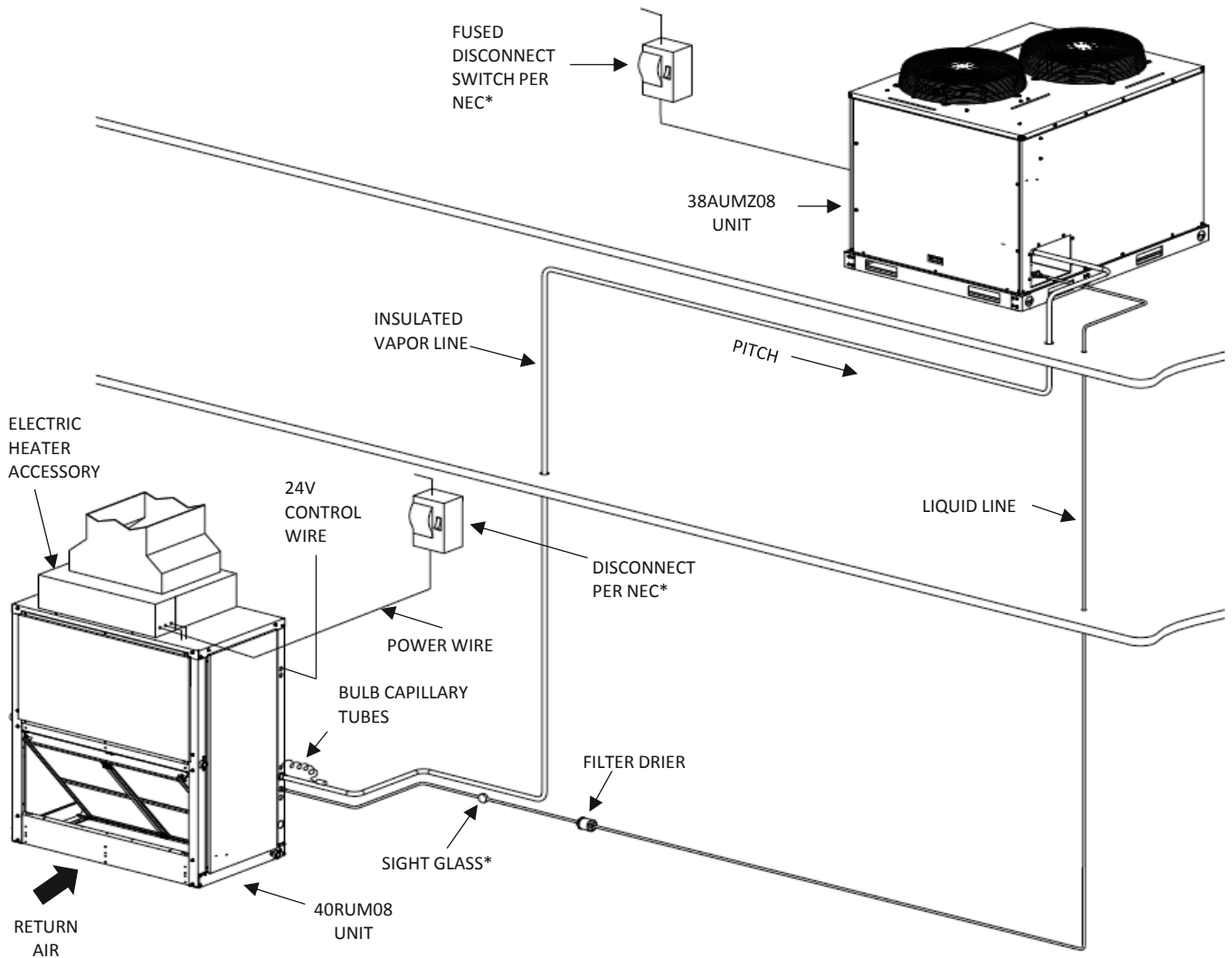

LEGEND:

NEC - National Electrical Code

TXV - Thermostatic Expansion Valve

 Piping

* Field supplied

NOTES:

1. All piping must follow standard refrigerant piping techniques. Refer to Carrier System Design Manual for details.
2. All wiring must comply with applicable local and national codes.
3. Wiring and piping shown are general points-of-connection guides only and are not intended for, or to include all details for, a specific installation.
4. Filter driers must be bi-flow type suited for heat pump duty.
5. Internal factory-supplied TXVs and check valves not shown.

APPLICATION DATA

Operating limits

Maximum fan speed
40RUM07-28 1200 RPM (20 R/S)

General

IMPORTANT: Do not bury refrigerant piping underground. Select equipment to match or to be slightly less than peak load. This provides better humidity control, less unit cycling, and less part-load operation. Equipment should be selected to perform at no less than 300 cfm/ton (40 L/s per kW).

The air handler fan must always be operating when the condensing unit is operating.

Ductwork should be sized according to unit size, not building load. For larger units with two fans, a split duct transition is recommended at the fan outlets, but a plenum can be used with slight reduction in external static pressure capability.

For variable air volume (VAV) systems with supply-to return air recycling, use the equipment room as a return air plenum.

Auxiliary Side Connector Data

40RUM Unit	Carrier P/N	INLET/OUTLET DIAMETER — ODF (in.)
07	EA19BA705	1 - 1/8
08	EA19BA905	1 - 3/8
12	EA19BA705	1 - 1/8
14	EA19BA705	1 - 1/8
16	EA19BA705	1 - 1/8
28	EA19BA905	1 - 3/8

Factory-Installed Nozzle And Distributor Data

40RUM Unit	Coil Type	TXV Qty...Part No.	Distributor Qty...Part No.	Feeder Tubes Per Distributor Qty...Size (in.)	Nozzle Qty...Part No.
07	4 Row	1...EA36UC050	1...EA07KC102	12...1/4	1...EA19CY904
08	4 Row	1...EA36UC060	1...EA07KC112	15...1/4	1...EA19CY905
12	4 Row	2...EA36UC040	2...EA07KC116	9...1/4	2...EA19CY903
14	4 Row	2...EA36UC050	2...EA07KC216	12...3/16	2...EA19CY903
16	4 Row	2...EA36UC060	2...EA07KC213	16...3/16	2...EA19CY904
28	4 Row	2...068H8834	2...EA07TC251	20...1/4	2...EA19CZ912

LEGEND

TXV - Thermostatic Expansion Valve

Standard Drive Data - 60Hz - SI

Unit	40RUM07	40RUM08	40RUM12	40RUM14	40RUM16	40RUM28
Motor Drive						
Motor Pulley Pitch Diameter (mm)	61.0-86.4	71.1-96.5	86.4-111.8	71.1-96.5	71.1-96.5	109.2-134.6
Pulley Factory Setting Full Turns Open	0	3	2.5	0.5	1.5	3
Fan Drive						
Pulley Pitch Diameter (mm)	224	224	224	229	229	279
Pulley Bore (mm)	25.4	25.4	25.4	36.5	36.5	49.2
Belt No. - Section	1-A	1-A	1-A	1-A	1-A	2-BX
Belt Pitch (mm)	1024	1049	1074	1074	1074	1087
Fan Speed (r/s)						
Factory Setting	9.5	10.8	12.7	10.5	10.5	12.5
Range	7.8-11.1	9.2-12.4	11.1-14.4	9.0-12.1	9.0-12.1	10.9-13.4
Max Allowable Speed (r/s)	20	20	20	20	20	18.3
Change Per 1/2 Turn Of Moveable Motor Pulley Flange	0.327	0.327	0.328	0.318	0.318	0.210
Max Full Turns From Closed Position	5	5	5	5	5	6
Shafts Center Distance (mm)	265-313	265-313	265-313	265-313	265-313	169-240

APPLICATION DATA (cont.)

Medium-Static Drive Data - 60Hz - SI

Unit	40RUM07	40RUM08	40RUM12	40RUM14	40RUM16
Motor Drive					
Motor Pulley Pitch Diameter (mm)	86.4-111.8	86.4 -111.8	86.4-111.8	86.4-111.8	94.0-119.4
Pulley Factory Setting Full Turns Open	2.5	2.5	2.5	2.5	3
Fan Drive					
Pulley Pitch Diameter (mm)	224	203	203	208	218
Pulley Bore (mm)	25.4	25.4	25.4	36.5	36.5
Belt No. - Section	1-A	1-A	1-A	1-A	1-B
Belt Pitch (mm)	1074	1024	1024	1049	1062
Fan Speed (r/s)					
Factory Setting	12.7	14	14	13.7	14
Range	11.1-14.4	12.2-15.8	12.2-15.8	11.9-15.4	12.4-15.7
Max Allowable Speed (r/s)	20	20	20	20	20
Change Per 1/2 Turn Of Moveable Motor Pulley Flange	0.328	0.36	0.36	0.352	0.278
Max Full Turns From Closed Position	5	5	5	6	6
Shafts Center Distance (mm)	265-313	265-313	265-313	265-313	265-313

High-Static Drive Data - 60Hz - SI

Unit	40RUM07	40RUM08	40RUM012	40RUM14	40RUM16
Motor Drive					
Motor Pulley Pitch Diameter (mm)	86.4-111.8	86.4-111.8	86.4-111.8	94.0-119.4	109.2-134.6
Pulley Factory Setting Full Turns Open	2.5	2.5	2.5	3	3
Fan Drive					
Pulley Pitch Diameter (mm)	178	152	152	188	201
Pulley Bore (mm)	25.4	25.4	25.4	36.5	36.5
Belt No. - Section	1-A	1-A	1-A	1-B	1-B
Belt Pitch (mm)	1049	947	947	1011	1011
Fan Speed (r/s)					
Factory Setting	16	18.7	18.7	16.3	17.7
Range	14.0-18.1	16.3-20.0	16.3-20.0	14.4-18.3	15.8-19.5
Max Allowable Speed (r/s)	20	20	20	20	20
Change Per 1/2 Turn Of Moveable Motor Pulley Flange	0.41	0.478	0.478	0.323	0.307
Max Full Turns From Closed Position	5	5	5	6	6
Shafts Center Distance (mm)	265-313	265-313	265-313	265-313	323-279

GUIDE SPECIFICATIONS

Commercial Packaged Air-Handling Unit

40RUM – Packaged Air Handler

Size Range: 6.0 to 28.0 Tons



Part 1 — General

1.01 SYSTEM DESCRIPTION

- A. Indoor, packaged air-handling unit for use in commercial split systems. Unit shall have a multi--position design and shall be capable of horizontal or vertical installation on a floor or in a ceiling, with or without ductwork. (Only vertical units are to be applied without ductwork.)
- B. Unit with direct-expansion coil shall be used in a refrigerant circuit with a matching air-cooled condensing unit. Unit with chilled water coil shall be used in a chilled water circuit.

1.02 QUALITY ASSURANCE

- A. Unit shall be rated in accordance with AHRI Standard 340/360 and SASO 2874/2016.
- B. Unit shall be in compliance with SASO 2874/2016.
- C. Unit shall achieve ASHRAE 90.1 minimum efficiency requirements (2010 version).
- D. Unit construction shall comply with ANSI/ASHRAE 15 safety code latest revision and comply with NEC.
- E. Unit shall be constructed in accordance with UL 1995 standard and shall carry the UL and UL, Canada label.
- F. Unit cabinet shall be capable of withstanding 500-hour salt spray exposure per ASTM B117 (scribed specimen).
- G. Unit shall be designed and manufactured in a facility in accordance and registered by ISO 9001:2015.

1.03 DELIVERY, STORAGE, AND HANDLING

Unit shall be shipped as single package only, and shall be stored and handled according to unit manufacturer's recommendations.

1.04 WARRANTY (FOR INCLUSION BY SPECIFYING ENGINEER.)

Part 2 — Products

2.01 EQUIPMENT

Indoor mounted, draw-thru, packaged air-handling unit that can be used in a suspended horizontal configuration or a vertical configuration. Unit shall consist of forward-curved belt-driven centrifugal fan(s), motor and drive assembly, pre-wired fan motor contactor, factory-installed refrigerant metering devices (direct-expansion coil units), cooling coil, 1 –in (25.4-mm) aluminum air filter, and condensate drain pans for vertical or horizontal configurations.

A. Base Unit:

- a. Cabinet shall be constructed of mill-galvanized steel.
- b. Cabinet panels shall be fully insulated with 1/2-in. (12.7-mm) fire-retardant closed cell polyolefin foam (ethylene) with density 32 ~ 40 kg/cu. meter reinforced with aluminum foil face. Insulation shall conform to NFPA 90A.
- c. Unit shall contain non-corroding condensate drain pans for both vertical and horizontal applications. Drain pans shall have connections on right and left sides of unit to facilitate field connection. Drain pans shall have the ability to be sloped toward the right or left side of the unit to prevent standing water from accumulating in pans.
- d. Unit shall have factory-supplied 1 –in (25.4-mm) aluminum air filter installed upstream from the cooling coil. Filter access shall be from either the right or left side of the unit.

B. Coils:

DX coil is 4-row and consists of copper tubes with sine-wave aluminum fins bonded to the tubes by mechanical expansion. Suction and liquid line connections or supply and discharge connections shall be made on the same side of the coil.

Direct-expansion coils shall feature factory installed thermostatic expansion valves (TXVs) for refrigerant control. The TXVs shall be Puron® R-410A compatible and capable of external adjustment. Direct-expansion heat pump coils shall have a factory-installed bypass line and check valve assembly around the TXVs to allow liquid flow from the coil to the outdoor unit during the heating mode. Coil tubing shall be internally rifled to maximize heat transfer.

C. Operating Characteristics:

Unit shall be capable of providing ____ cfm (L/s) airflow at an external static pressure of ____ in. wg (kPag).

D. Motor:

- a. Fan motor of the size and electrical characteristics specified on the equipment schedule shall be factory supplied and installed.
- b. Motors rated at 2.4 through 2.9hp (1.79 through 2.16 hp) shall have internal thermal overload protection. Motors rated at 5 hp (3.73 kW) shall be protected by a circuit breaker.
- c. Evaporator-fan motor shall have permanently lubricated, sealed bearings and inherent automatic-reset thermal overload protection or manual reset calibrated circuit breakers. Evaporator motors are designed specifically for Carrier and do not have conventional horsepower (hp) ratings listed on the motor nameplate. Motors are designed and qualified in the "air-over" location downstream of the cooling coil and carry a maximum continuous bhp rating that is the maximum application bhp rating for the motor; no "safety factors" above that rating may be applied.

E. Features:

- a. Alternate Motor and Drive:
An alternate motor and/or medium-static or high-static drive shall be available to meet the airflow and external static pressure requirements specified on the equipment schedule.
- b. Electric Heaters:
Heaters shall be factory-supplied for field installation as shown on the equipment drawings. Electric heat assembly shall be ETL (U.S.A.) and ETL, Canada, agency approved, and shall have single-point power wiring. Heater assembly shall include contactors with 24-v coils, power wiring, 24-v control wiring terminal blocks, and a hinged access panel. Electric heaters shall not be used with air discharge plenum.
- c. Air Discharge Plenum:
Plenum shall be factory-supplied to provide free-blow air distribution for vertical floor-mounted units. A grille with moveable vanes for horizontal or vertical airflow adjustment shall be included. Plenum shall be field-assembled and field-installed on the unit's fan deck for blow-thru air distribution. Plenum shall not be used with electric heaters.
- d. Return-Air Grille:
Grille shall be factory-supplied for field installation on the unit's return air opening.
- e. Unit Subbase:
Subbase assembly shall be factory-supplied for field installation. Subbase shall elevate floor-mounted vertical units to provide access for correct condensate drain connection.
- f. Thermostat Controls:
 - i. TEMP System programmable communicating multi-stage thermostat with fan switch, time clock, LCD display, °F/°C capability, and CCN (Carrier Comfort Network®) compatibility.
 - ii. Commercial Electronic Thermostat with 7-day time clock, auto-changeover, multi-stage capability, and large LCD temperature display.
- g. Overhead Suspension Package:
Package shall include necessary brackets to support units in a horizontal ceiling installation.
- h. Condensate Drain Trap:
Trap shall have transparent, serviceable design for easy cleaning. Kit shall include overflow shutoff switch and wiring harness for connection to an alarm if desired.
- i. UV-C Germicidal Lamps:
 - i. UV-C emitters and fixtures shall be specifically designed for use inside an HVAC system. An ASME nozzled test apparatus using a 45°F (7.2°C) airstream moving at not less than 400 fpm (189 liters/sec.) shall measure individual lamp output. Lamp output at 253.7 nm shall not be less than 10μW/cm² per inch of arc length measured at a distance of one meter.
 - ii. UV-C power supplies shall be high efficiency, electric type which are matched to the emitters and are capable of producing the specified output intensity with an input power no more than 80 watts.
 - iii. Emitters and fixtures shall be installed in sufficient quantity and arranged so as to provide an equal distribution of UV-C energy on the coil and drain pan.
 - iv. The minimum UV-C energy striking the leading edge of the coil fins shall be not less than 820 μW/cm² at the closest point and through placement, not less than 60% of that value at the farthest point. Equal amounts are to strike the drain pan, either directly or indirectly through reflection.

NOTES

